

H7012A Humidity and H7012B Humidity and Temperature Room Sensors

PRODUCT DATA



FEATURES

- Pt 1000, NTC 20k Ω , or 0...10 V temperature sensing element
- Wide sensing range
- Capacitance-type sensing element for relative humidity
- Two-piece plug-in design. The wiring sub-base allows installation and wiring independent of the front element, which includes the electronics and plugs-into the wiring sub-base.
- The H7012BALCO500KIT (ordered separately) allows you to expand the H7012A1010 wall module with a BALCO 500 Ohm temperature sensor. The H7012BALCO500KIT contains five (5) BALCO 500 sensor elements plus adhesive strips.

GENERAL

The H7012A Room Humidity Sensor is a capacitance-type relative humidity sensor for wall mounting.

The H7012B Combined Room Humidity/Temperature Sensor incorporates a capacitance-type relative humidity sensor with a Pt 1000, NTC 20k Ω , or 0...10 V temperature sensor in one housing for the measurement of room temperature and relative humidity.

These sensors are used for control, indication, and alarm monitoring in air conditioning installations.

MODELS

OS-No.	temperature sensor type	sensing ranges
H7012A1010	-	5...95%rh
H7012B1008	Pt 1000	5...95%rh and 0...50 °C
H7012B1024	NTC 20k Ω	
H7012B1030	0...10 VDC output	
H7012BALCO500KIT	BALCO 500 exchange kit for H7012A1010	0...50 °C

SPECIFICATION

Power supply	24 Vac, +20...-30%; 50/60Hz, 34 Vdc, +20...-30%
Current consumption	20 mA at 24 V

Ambient limits

Operating temperature	0...50 °C (32...122 °F)
Transport and storage temperature	-25...+70 °C (-13...+158 °F)
Humidity	5...95%rh, non-condensing
Dustiness	not suitable for dusty environments

Safety

Protection class	II in acc. with EN60730-1
Protection standard	IP30 in acc. with EN60529
Housing material	Flame retardant V0 as per UL94

Housing

Dimensions (H x W x D)	130 x 80 x 34 mm (5.12 x 3.15 x 1.34")
Weight	130 g
Mounting	Wall, surface, or European outlet box

Temperature Sensor

Nominal value	
– Pt 1000	1000Ω at 0 °C
– BALCO 500	500Ω at 23.3 °C
– NTC 20kΩ	20kΩ at 25 °C
Accuracy	
– Pt 1000	$\Delta T/K = \pm(0.3 + 0.005 \cdot t)$ [t in °C] as per DIN IEC 751 Class B
– BALCO 500	±0.4 K at 23.3 °C
– NTC 20kΩ	±0.2 K at 25 °C
Sensitivity	
– Pt 1000	≈ 3.85Ω / K
– BALCO 500	2Ω / K
– NTC 20kΩ	non-linear characteristic
Characteristic	Response time at air velocity 0.02...0.07m/s
– τ _{0.5} Pt 1000	≈ 50 s
– τ _{0.5} Balco 500	≈140 s
– τ _{0.5} NTC	≈134 s
0...10 V active sensor	≈ 0...50 °C

Relative Humidity Sensor

Output signal	0...10 Vdc ≈ 0...100%rh
Output impedance	10 V range 274Ω
Outputs short-circuit protected	
Sensitivity	10 mV / %rh or 100 mV / %rh
Accuracy	at 25 °C / 24 Vac
	5...10%rh ±10%
	10...30%rh ± 5%
	30...70%rh ± 3%
	70...90%rh ± 5%
	90...95%rh ±10%
Response time	τ _{0.5} = 20 s

DIMENSIONS

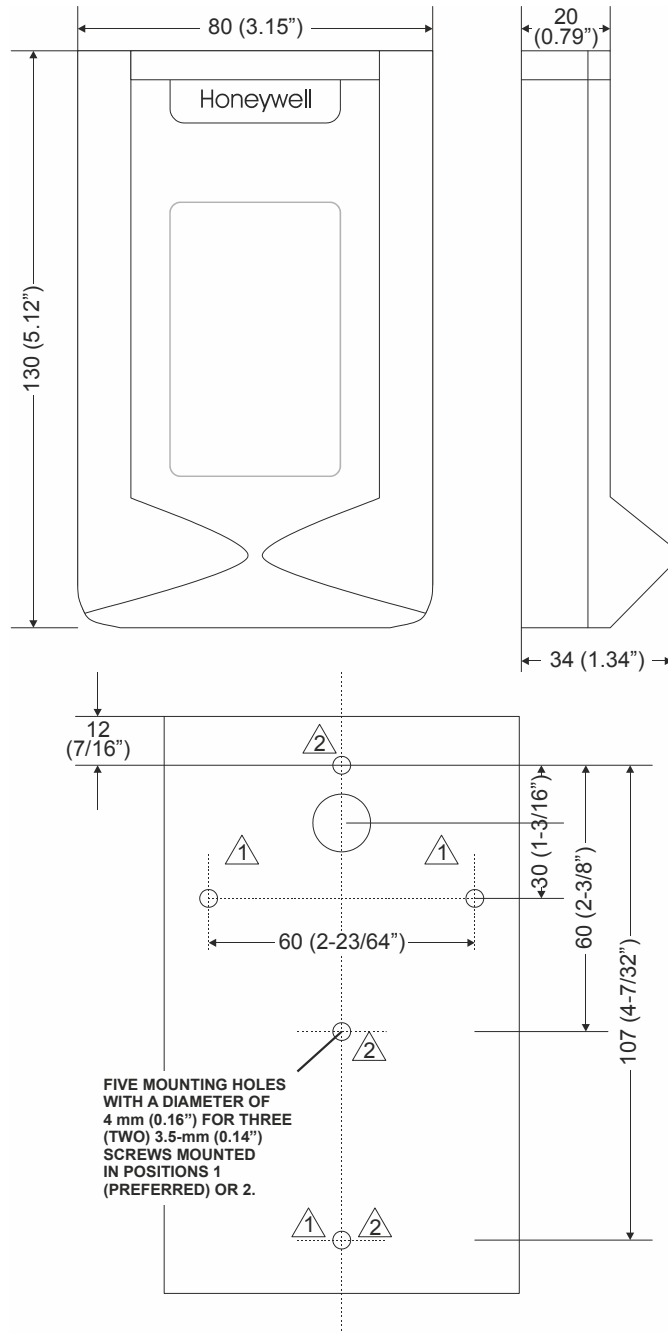

Fig. 1. Dimensions (in mm and inches) and drilling template

INSTALLATION

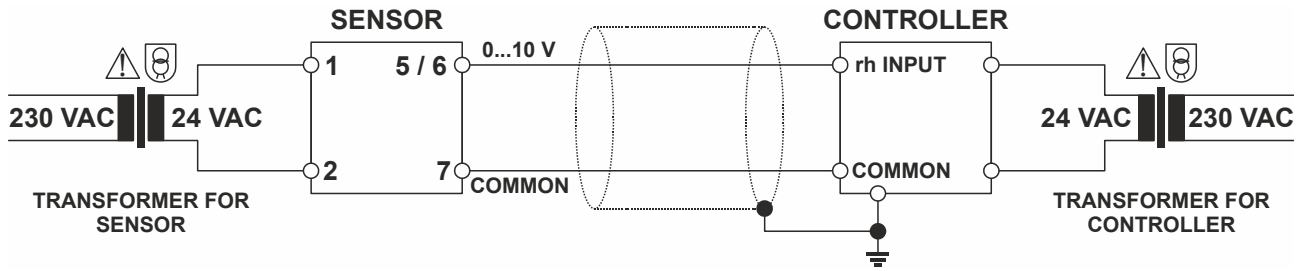

Fig. 2. Installation example

Mounting and Installation Advice

- Mount these units at the inside wall of the room to be heated or air conditioned, away from doors, windows and heat sources.
- It should be located approx. 1.5 m above the floor and at minimum 50 cm away from the next wall.
- Do not mount in niches, book shelves, behind cabinets or curtains or where it could be exposed to solar radiation.
- Seal the conduit opening to avoid false temperature measurement due to draught from the conduit.
- Provide sufficient air circulation.

Wiring

wiring run	max. length
sensor to controller	200 m (660 ft)

Offset due to wire resistance per 10 m distance from sensor to controller:

type of wire	temperature offset		
	Pt 1000	BALCO 500	NTC
0.5 mm ² (AWG20)	0.18 K (0.324 °F)	0.3 K (0.54 °F)	negligible
1.0 mm ² (AWG17)	0.09 K (0.162 °F)	0.15 K (0.27 °F)	
1.5 mm ² (AWG15)	0.06 K (0.108 °F)	0.1 K (0.1 °F)	

NOTE: Use shielded wiring in areas with high EMI. Keep 15 cm (5.9") minimum distance between sensor lines and 230Vac power lines. Use two transformers: one for sensors and actuators and one for the controller (see example).

Wiring Connection

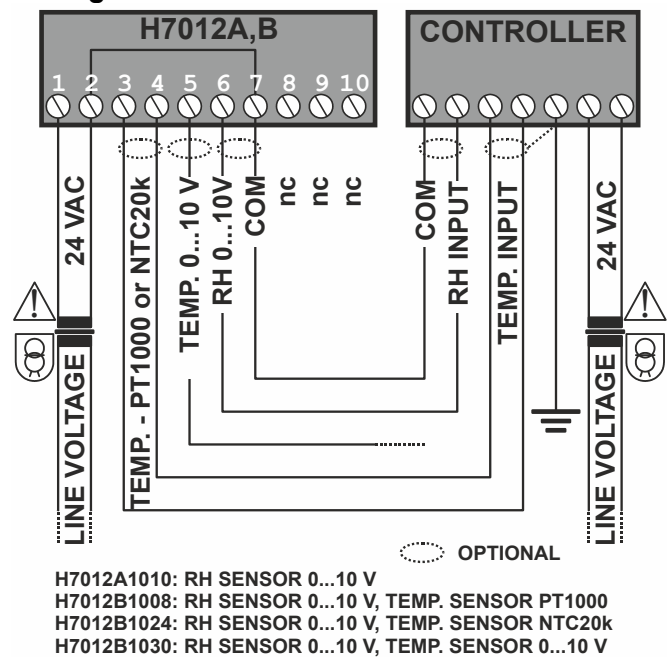

Fig. 3. Wiring connection

Honeywell

Manufactured for and on behalf of the Environmental and Combustion Controls Division of Honeywell Technologies Sàrl, Rolle, Z.A. La Pièce 16, Switzerland by its Authorized Representative:

Automation and Control Solutions

Honeywell GmbH
 Böblinger Strasse 17
 71101 Schönaich / Germany
 Phone: (49) 7031 637 - 01
 Fax: (49) 7031 637 - 493
<http://ecc.emea.honeywell.com>
 Subject to change without notice. Printed in Germany
 ENOB-0698GE51 R0313