

TECHNICAL MANUAL DUAL TRANSDUCER AMPLIFIER MANUAL TYPE 621

Doc. Ref CD2002R

This manual applies to units of mod status 12 ONWARDS



BS EN ISO 9001
Certificate No. FM13141



Affirmed by Declaration
of Conformity

INDEX

1.	INTRODUCTION	3
1.1	BEFORE POWERING-UP CHECK.....	4
1.2	Information on Conformity to EC Directives.	4
2.	TRANSDUCER AND OUTPUT CONNECTIONS	5
2.1	Transducer connections with 600 Backplane.	5
2.2	Connections for LVDT displacement Transducer (with backplane).....	5
2.3	Connections for Half Bridge displacement Transducer (with backplane)	5
2.4	Connections for Analogue Outputs (with backplane)	5
2.5	Output connections via front panel jack plug.	6
2.6	Input and Output Connections (Without M600 Backplane)	6
3.	CONTROL LOCATIONS.....	8
3.1	Gain Range Switches	8
3.2	Fine Gain Potentiometers.....	8
3.3	Zero Range Switches	8
3.4	Fine Zero Potentiometers.....	9
3.5	Zero Input Switches.....	9
3.6	Channel Number (Address) Switch	9
3.7	Frequency Resistor	9
3.8	Output Voltage/Current Selector	9
3.9	Half-Bridge/Differential Completion Resistors	9
3.10	Master/Slave.....	9
3.11	LEDs.....	10
4.	SETTING UP PROCEDURE.....	10
5.	A-B OR A+B MEASUREMENT	12
6.	SPECIFICATION	12
7.	ISOLATED OUTPUT OPTION G.....	13
8.	SAMPLE/HOLD OPTION SH.....	14
9.	WARRANTY AND SERVICE	16

Table of Figures

Fig. 1	Front Panel.....	4
Fig. 2	Control Locations	7

1. INTRODUCTION

The 621 is a 2-channel LVDT oscillator/demodulator which may also be used with half-bridge and similar inductive-type transducers. There is a common excitation supply, but each channel has separate gain and zero controls and outputs which are selectable for voltage or current (4-20mA).

Connections are made via a rear-mounted 32-way DIN 41612 edge connector, or, when used with an M600 backplane, via circular DIN (audio type) plugs. Output signals are also provided on a front-mounted jack which, together with fine gain and zero controls, are accessible via holes in the panel.

Push-button zero-input switches allow easy checking of amplifier zero adjustments and a master/slave facility removes beating effects in multi-channel systems.

Various excitation voltages and frequencies are easily obtained via link/resistor changes. This, together with the gain range switches and zero range switches, allows use with the complete range of RDP LVDTs and half-bridge transducers.

A bi-colour LED gives an approximate indication of armature central position.

When used with the RDP type 600 Backplane and 635/6/650 Monitor units, separate multiplexed output and excitation signals are automatically selected via an on-board decoding circuit for connection to the monitor signal bus.

Options include isolated output which provides full galvanic isolation to 500v (suffix G) and fast analogue sample and hold (suffix S).

SPECIAL NOTE Master/Slave

1. If this module has been supplied in an RDP housing then it will have been configured as a master or slave as required. To avoid beat-frequency effects only one module per system is configured as a master to control excitation frequency of all other modules. In a system the master is generally the first module (channel 1), top rack of 605/6/7 systems.
2. If this module has been purchased on its own, it will be supplied as a stand-alone unit and can be added to an existing system as it is.
3. If this module needs to be made a slave before adding to an existing system (to eliminate any possible beating effects) then see section 3.10.

NOTE: 621 modules of Mod 11 onwards cannot be made slaves to older pre-Mod 11 modules. If in doubt, contact RDP.

1.1 BEFORE POWERING-UP CHECK...

1	The supply voltage is correct to suit the 631/632 unit fitted and input range selected
2	The various plug-in modules are in the correct positions in the housing.
3	The input and output plugs are in the correct sockets. Note that on the housing back-plane all input sockets and all output sockets are of the same type.
4	That each module has a unique address. (see section 3.6)
5	The master/slave link is correctly set (see section 3.10)

NOTE: Ensure system is switched OFF when removing or replacing modules in rack and ensure each module has a unique address. Failure to do so may cause damage to modules.

1.2 Information on Conformity to EC Directives.

This module is not CE marked because it is intended for use as a component of a larger system. RDP CE mark full modular 600 systems that includes a 60X housing and a 63X power supply where the system is fully populated with either 600 series amplifier/display modules or blank panels.

If the module is part of a full 600 system, refer to the system manual (CD2010) for CE certification.

If the module is not part of the full 600 system, it is the responsibility of the organization / individual producing the system to assess and/or test EMC compatibility.

Fig. 1 Front Panel

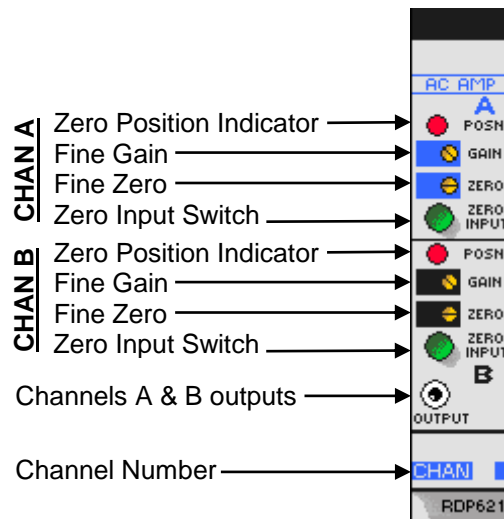

2. TRANSDUCER AND OUTPUT CONNECTIONS

2.1 Transducer connections with 600 Backplane.

(Refer also to System Manual CD2010)

The backplane (rear panel) connectors are arranged in columns of three. Each channel is identified with its number and each connector with a letter - A & B are for the two transducer inputs, where the module is a dual input amplifier, and C identifies the output connector.

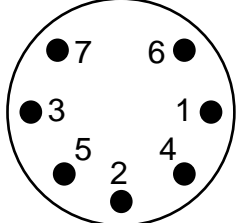
When the 621 is used with the RDP Backplane, transducer connections are made via circular DIN connectors as follows: 7-pin Channel A connectors 1A to nnA, and 7-pin Channel B connectors 1B to nnB		Input connector (viewed from rear.)
---------------------------------------------------------------------------------------------------------------------------------------------------------------------------------------------------------------	------------------------------------------------------------------------------------	-------------------------------------

2.2 Connections for LVDT displacement Transducer (with backplane)

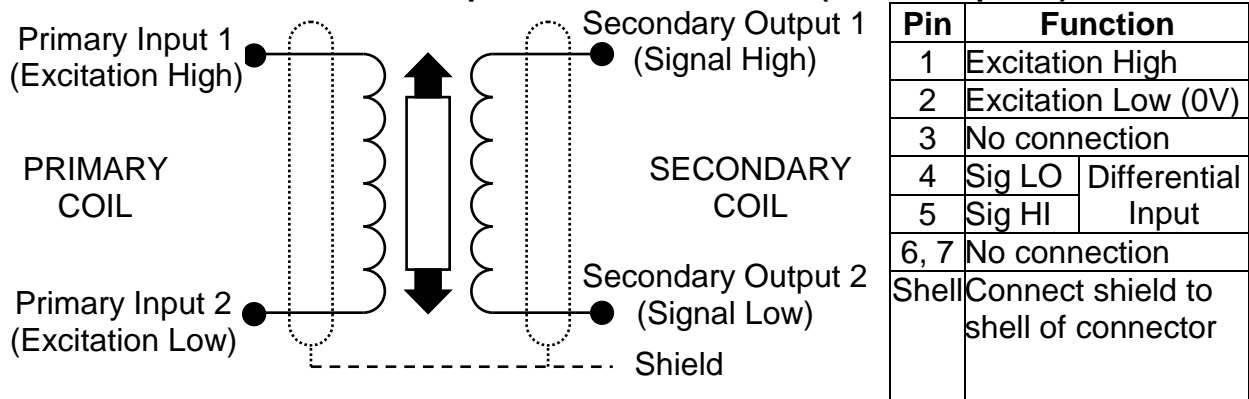

2.3 Connections for Half Bridge displacement Transducer (with backplane)

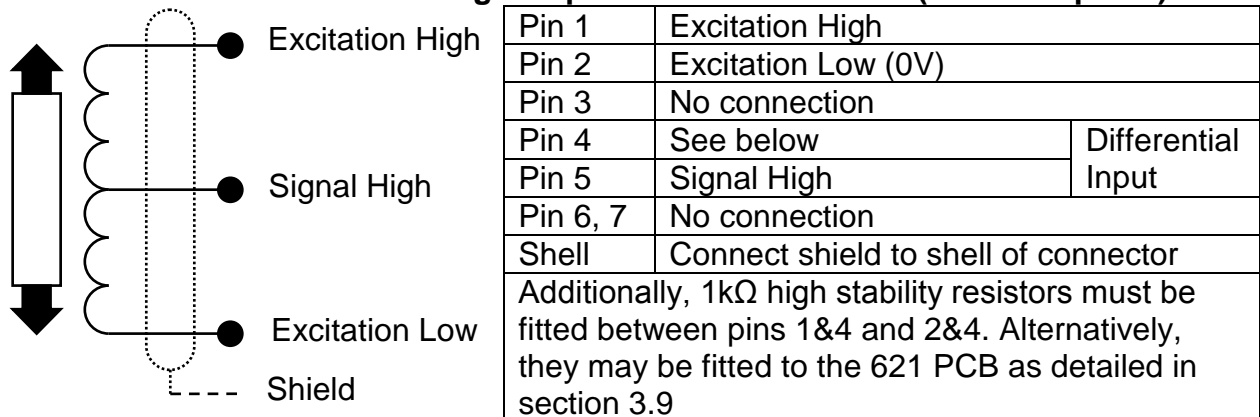

2.4 Connections for Analogue Outputs (with backplane)

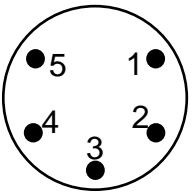
Output connector (viewed from rear.)		Outputs: 5-pin Connectors (labelled 1C to nnC)
		Pin 1 Channel A Output
		Pin 2 Output Common (0V)
		Pin 3 Channel B Output
		Pin 4 Isolated Output Common (Optional)
		Pin 5 No connection

2.5 Output connections via front panel jack plug.

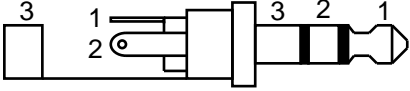
	PIN	FUNCTION
	1	Channel B output
	2	Channel A output
	3	Output Common (0V)

Note: Front panel jack plug always provides voltage output, irrespective of whether voltage or current output is selected on PCB.

2.6 Input and Output Connections (Without M600 Backplane)

The **DIN 41612** 32-way connector details are:

PIN	Function	Comments	
1	Excitation High	Channel A Transducer	
2	Excitation Low (0V)		
3	0V (Shield)		
4	Signal Low		Differential
5	Screen High		
6	No connection		
7	No connection		
8	Channel A Output	Outputs	
9	Channel Common (0V)		
10	Channel B Output		
11	Excitation High	Channel B Transducer	
12	Excitation Low (0V)		
13	0V (Shield)		
14	Signal Low		Differential
15	Signal High		
16	No connection		
17	No connection		
18	Channel A Output	Multiplexed for use with 635/6 only	
19	Channel B Output		
20	Excitation Output		
21	Master/Slave		
22	Output Hold		
23	Limits Reset/Isolated Output 0V		
24/27	Channel Address	Used with 635/6 only	
28	+5VD		
29	0VD		
30	+15V		
31	-15V		
32	0VA		

Fig. 2 Control Locations

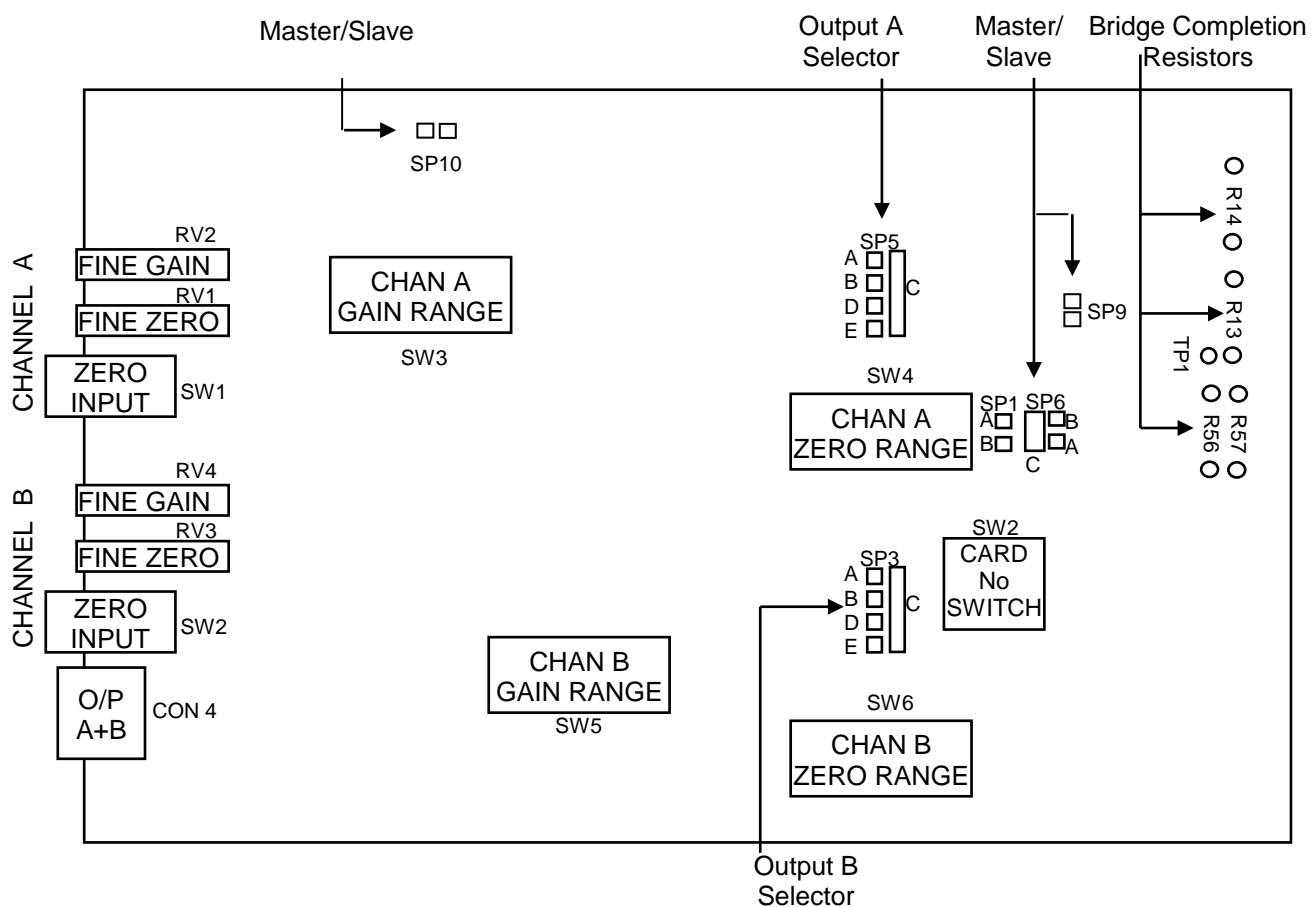

NOTE:

SP9 and SP10 on rear of PCB.

3. CONTROL LOCATIONS

(Refer also to Fig.2 for locations)

3.1 Gain Range Switches

On units up to Mod 10K these are DIL slide switches which increase amplifier gain by about x3 for each position from 1 to 8.

On units from Mod 11 onwards these are 4-way DIL toggle switches where the same 8 gain ranges are available. When used with the fine gain potentiometer. It allows a continuous gain variation covering a wide range of transducer signals as shown below.

Up to Mod 10K	Mod 11 onwards	Input Signal Range (V rms)	
		For $\pm 10V$ output	For 4-20 mA output
Switch Position	Toggles ON		
1	1	4V max. See Note 1	4V max
2	1 + 2	4V max. See Note 1	2-4V
3	1 + 3	2-4V max.	1-2V
4	1 + 4	0.7 – 2.4V	0.35 – 2.2V
5	None	260-850 mV	130-430 mV
6	2	90-290mV	45-150mV
7	3	33-100mV	16-50mV
8	4	12-38mV	6-20mV
Note 1:	Ranges 1 and 2 are used to produce lower outputs than $\pm 10V$, with high input signals, eg for scaling the 635/6 monitors with full scale values much lower than the 19999 maximum. For example, to display 20.00 full scale with a 3v signal, using range 3 would not allow an output of <5v (50.00 display). Hence range 2 is required.		

3.2 Fine Gain Potentiometers

These are 20-turn, screwdriver-adjusted controls providing about 3:1 gain change, to interpolate between ranges of the gain switches.

3.3 Zero Range Switches

These are 6-way DIL toggle switches used to inject different amounts of zero suppression of the output signal, e.g. to obtain a unipolar output signal from a bipolar LVDT. The amplitude and polarity of the output shift provided by the various settings are shown below. Note these will vary according to the Fine Gain setting.

Toggles ON	Approximate Output Voltage Shift in Volts
None	0
1	+2 to +7
1 + 3	+4 to +10
1 + 4	+6 to +10
1 + 5	+8 to + 10
2	-2 to -7
2 + 3	-4 to -10
2 + 4	-6 to -10
2 + 5	-8 to -10

3.4 Fine Zero Potentiometers

These are 20-turn, screwdriver-adjusted controls providing a small adjustment of amplifier output offset to interpolate between the ranges of the Zero Range Switches.

3.5 Zero Input Switches

These are momentary action push-buttons which switch the amplifier input signal to zero volts, irrespective of the transducer signal. This allows a true amplifier output zero to be obtained. Refer also to Section 3.11.

3.6 Channel Number (Address) Switch

This is a 16-way (hexadecimal), screwdriver-adjusted rotary switch scaled 0 to F. when the module is used in a system with a backplane, the individual channel number must be set on this switch. Each module must have a different number set to avoid signal contention on the A, B and E (excitation) output busses to the monitor. **Failure to do so may cause damage to modules.**

For example, if the switch is set to 1 then, when the monitor switch is set to 1, only the outputs of No.1 are enabled and connected to the monitor. Similarly, for numbers 2 - 9. For modules 10 - 15, the switch positions A - F are used, as shown below:

Module No	1	2	3	4	5	6	7	8	9	10	11	12	13	14	15
Switch Posn	1	2	3	4	5	6	7	8	9	A	B	C	D	E	F

3.7 Frequency Resistor

On units up to Mod 10K, the excitation frequency may be changed by changing one resistor R5.

On units from Mod 11 onwards, this facility is not available. Other excitation frequencies are available but must be stated when ordering.

3.8 Output Voltage/Current Selector

Solder pads allow selection of voltage & current output, i.e. SP5 for Channel A and SP3 for Channel B.

For voltage output, link B - C,
For 4-20mA output, link D - C.

3.9 Half-Bridge/Differential Completion Resistors

When using this type of transducer, the amplifier input bridge circuit must be completed by fitting two extra resistors. For Channel A these are R13 and R14. For channel B, R56 and R57. These should be high stability types (e.g. $\pm 0.1\%$ 15ppm) and the normal value is 1k Ω .

3.10 Master/Slave

To eliminate beating effects in multi-channel systems, any one of the modules may be designated as a master oscillator, with all other as slaves synchronised to the master.

	SP6	SP9	SP10
Master	Link B-C	Made	Removed
Slave	Link A-C	Removed	Made

To complete the master/slave connections, pin 21 of each module must be linked together. When a 600-type backplane is used, this automatically links pin 21.

NOTE: 621 modules of Mod 11 onwards cannot be made slaves to older pre-Mod 11 modules. If in doubt, contact RDP.

3.11 LEDs

These are bi-colour indicators mounted on the front of the module. They change from green to red as the armature passes centre-stroke from in to out. This may be used as an approximate indication only.

4. SETTING UP PROCEDURE

Note: To obtain the specified transducer accuracy, the armature must operate within the linear range with reference to the datum point determined by step 4.4.

- 4.1 Determine the transducer output from the manufacturer's data and set the Coarse Gain control as shown in Section 3.1.
- 4.2 Connect the transducers as detailed in Section 2. Switch ON power and allow a 15-minute warm up period (for maximum accuracy).
- 4.3 Press the ZERO/INPUT switch and adjust the ZERO controls for zero output as shown in Section 3. (For 4-20mA outputs, "zero output" = 4mA.) Release the switch.
- 4.4 Adjust the transducer armature for zero output (4mA). The FINE ZERO control may be used to obtain an absolute zero indication if the armature adjustment is too coarse. This determines the transducer centre-stroke position. **THIS IS AN IMPORTANT STEP whatever the final stroke/output calibration requirement.**

Now proceed with either 4.5, 4.6 or 4.7 according to application.

4.5 Voltage Output Half-Stroke Operation

- (a) Move the transducer armature by a precise amount (e.g. 0.200 inches for a D5/200 transducer) and adjust the FINE GAIN control for the desired output, e.g. 10v.
- (b) Relocate the transducer armature at the centre of the stroke and check that the output is zero. Re-adjust the FINE ZERO control if necessary.

Repeat (a) and (b) for consistent results.

- (c) Move the armature to the full-scale position in the opposite direction and check for, e.g. -10v output.

4.6 Voltage Output Full Stroke Operation

If it is required that the transducer be used over its entire working range in one direction, e.g. 0 to 0.4 inches for a D5/200 transducer, then the zero controls are used to "back off" the signal equivalent to 0.200 inches.

- (a) Set up as in 4.5, i.e. $\pm 5V$ output for ± 0.2 inches using a D5/200.
- (b) Move the armature by exactly 0.200 inches (for a D5/200 transducer) and then adjust the ZERO controls to back-off this signal to zero. Now move the armature back 0.400 inches and adjust the FINE GAIN control for the required output.

- (c) Repeat (b) until consistent results are obtained. If, for any reason, the coarse gain is changed, restart the whole procedure.

4.7 Current Output

- (a) Move the transducer by a precise amount (eg 0.200 inches for a D5/200 transducer) and adjust the FINE GAIN control for 12 mA.
- (b) Move the armature to the full-scale position in the opposite direction and adjust the FINE ZERO control (and COARSE ZERO control if necessary) for 4mA.
- (c) Relocate the transducer armature to the original full-scale position used in (a) and check the output is 20mA. Re-adjust the FINE GAIN control if necessary.
- (d) Repeat (b) and (c) for consistent results.

4.8 Differential Inductance Transducers

Setting up procedure is similar to that described for LVDTs above.

5. A-B OR A+B MEASUREMENT

A difference or sum output may be obtained by monitoring the output between the Output A and Output B pins. To swap between difference and sum, swap the secondary connections to one of the transducers.

6. SPECIFICATION

Number of Channels:	2 (A and B), common excitation
Supply:	$\pm 15\text{V}$ ($\pm 0.6\text{V}$) unregulated, 65mA typical, no load.
Excitation:	1.1V, 5kHz, 100mA max
Signal Range:	12mV to 4V in 8 ranges for $\pm 10\text{V}$ output
Input Impedance:	100k ohms
Zero Range:	$\pm 100\%$ of output
Output linked for	$\pm 10\text{V}$ into 2k ohm (min.)
V	4 - 20mA into 0 - 450 ohm. This is an active output that
I	must not be connected to any external power supply as
	this will damage unit.
Ripple (Voltage output):	10mV p-p typical
(Current output):	100 μA p-p
Bandwidth:	400Hz flat
Linearity:	$\pm 0.05\%$ typical
Crosstalk:	0.01% maximum effect
Operating Temperature:	0 – 60°C
Zero Tempco:	0.005% FS/°C typical
Gain Tempco:	0.005% FS/°C typical. Optimum at $\pm 10\text{V}$ output.
Dimensions:	160 x 100 x 15mm (Eurocard) (6.3 x 4 x 0.6 inches)
Front Panel:	128 x 25mm (5 x 1 inches)

7. ISOLATED OUTPUT OPTION G

This is an add-on pcb which galvanically isolates the amplifier output signal.

Output signal connections are detailed in Section 2, i.e. signals A and B on pins 1 and 3 of the 5-pin backplane connector C, as normal, but the output common signal is now at pin 4 with pin 2 not used.

Note: Channel A and Channel B 0v outputs are commoned internally; there is no isolation between amplifier channels A and B.

Option boards are normally supplied set for $\pm 10\text{v}$ output signals. To use the 4-20mA output, change SP1 and 2 on the option board to B-C. No change is required to the main pcb.

If the option board is to be retro-fitted to an existing 621, then to change the output from normal to isolated, the following links need changing on the main boards:

SP5 and SP3 to E-C.

The option board has unity gain (fixed) for voltage outputs so the setting-up procedure is as for normal units. Single-turn potentiometers provide a small adjustment of offset and gain for the 4-20mA outputs as follows:

RV1 set 4mA for channel A
RV2 set 20mA for channel A
RV3 set 4mA for channel B
RV4 set 20mA for channel B

Note: these are normally factory-set so that the normal output to 4-20mA output is:
+10v normal = 20mA
0v normal = 4mA.

Specification:

As for 621 with the following amendments and additions:

Output, current mode:	4-20mA into 0-400 Ω (lower loop resistance)
Isolation voltage:	500V dc
Resistance:	500M Ω
Output Noise:	Has an additional high frequency component (spikes) of typically 20mV rms which could generally be disregarded
Gain (of extra isolation amplifier):	1 : 1 $\pm 0.05\%$ typical (0.5% max.)
Zero Offset:	$\pm 20\text{mV}$ typical

8. SAMPLE/HOLD OPTION SH

This provides a fast, analogue sampling or hold of the 621 output signal. An external TTL signal is applied to the hold input as follows:

Hold signal high(or open circuit): Normal operation – output follows transducer signal

Hold signal low: HOLD mode – output holds the value extant at the moment of application. Output droops as detailed in the specification.

Note 1:

With no connection to the hold line, internal pull-up resistors allow the amplifier to operate normally.

Note 2:

TTL signal referred to 0vD pin 29.

For sample/hold operation the following solder links need changing, if not factory-set
Change SP5, SP3 to A-C.

Connections

The hold signal is connected via an extra 8-pin connector on the rear panel. Pin 1 is hold signal and pin 3 is 0v (common).

Specification

Response Speed: 20 μ seconds typical

Output Droop: <2mV (0.01% FS) per second typical

Hold Step Error: <0.1% FS typical

TTL Load: 10 μ A maximum plus 47k pull-up per board

Notes

9. WARRANTY AND SERVICE

WARRANTY.

R.D.P. Electronics products are warranted against defects in materials or workmanship. This warranty applies for one year from the date of delivery. We will repair or replace products that prove to be defective during the warranty period provided they are returned to R.D.P. Electronics.

This warranty is in lieu of all other warranties, expressed or implied, including the implied warranty of fitness for a particular purpose to the original purchaser or to any other person. R.D.P. Electronics shall not be liable for consequential damages of any kind.

If the instrument is to be returned to R.D.P. Electronics for repair under warranty, it is essential that the type and serial number be quoted, together with full details of any fault.

SERVICE.

We maintain comprehensive after-sales facilities and the instrument can, if necessary be returned to our factory for servicing.

Equipment returned to us for servicing, other than under warranty, must be accompanied by an official order as all repairs and investigations are subject to at least the minimum charge prevailing at the date of return.

The type and serial number of the instrument should always be quoted, together with full details of any fault and services required.

IMPORTANT NOTES.

1. No service work should be undertaken by the customer while the unit is under warranty except with the authorisation of RDP Electronics.
2. If the instrument is to be returned to R.D.P. Electronics for repair, (including repair under warranty) it is essential that it is suitably packed and that carriage is insured and prepaid. R.D.P. Electronics can accept no liability whatsoever for damage sustained during transit.
3. It is regretted that the above warranty only covers repairs carried out at our factory. Should the instrument have been incorporated into other equipment that requires our engineers to perform the repair on site, a charge will be made for the engineer's time to and from the site, plus any expenses incurred.

The aforementioned provisions do not extend the original warranty period of any product that has been either repaired or replaced by R.D.P. Electronics.

**THIS WARRANTY MAY BE NULL AND VOID SHOULD
THE CUSTOMER FAIL TO MEET OUR TERMS OF PAYMENT.**