



ENG

www.phytron.eu/phyBASIC

phyBASIC™

Precision Stepper Motor with High Torque and Smooth Running

Our motor series *phyBASIC™* combines the advantages of a price-optimised design with excellent operating characteristics. That makes the *phyBASIC™* motors particularly suitable for standard applications in the manufacturing industries. Good running performance, high torque and solid craftsmanship make the *phyBASIC™* an excellent choice for environments up to IP 40 when it comes to quick precise positioning tasks. Through the 200-step design, the optimised metal sheet cut and the smooth running the motor is also suitable for high precision applications.

More than just a standard

To help you find the perfect solution for your project, we offer you the opportunity to realise individual changes on the basis of our motor series. If *phyBASIC™* or the VSS in vacuum series is not sufficiently adapted to your application, we will develop one of our motors to the "perfect fit" for your application.

Combined with our modular motion controller *phyMOTION™*, the driver 1-STEP-Drive (for SIMATIC® ET200® S) or our amplifiers you will receive a perfectly tuned system of high quality motors, power amplifiers and controllers. Through a careful selection of suppliers and our certified quality system (ISO 9001), we make sure that *phyBASIC™* motors meet our high quality requirements and can be reliably used together with our electronics. You receive accustomed high phytron quality at good prices - bundled with our excellent support!

With our vast application experience of drives e.g. in paper production or even satellite optics we have the know-how to move your application.

RoHS
compliant

CE

In Focus



high precision



high torque



smooth running

- 2-phase stepper motors
- Holding torques from 16 mNm to 7.2 Nm
- Edge dimension from 20 to 86 mm
- Number of steps (standard) 200
- Step accuracy
5 % for 1.8° stepper motors
- Operating voltage
phyBASIC™ 20,28,42 (NEMA 8,11,17):
48 V_{DC}
phyBASIC™ 56,86 (NEMA 23/34):
72 V_{DC}
- Standard connection: 4-lead parallel
- Protection class IP 40
- Insulation class B, 130 °C
- Insulation resistance 100 MΩ
- Operating temperature range
-10 to +50 °C (non-freezing)
- Cable with mating connector included
- Options
 - Gear
 - Rear shaft

Industrial

Stepper motor *phyBASIC™* 20 to 86 (NEMA 8 to 34)

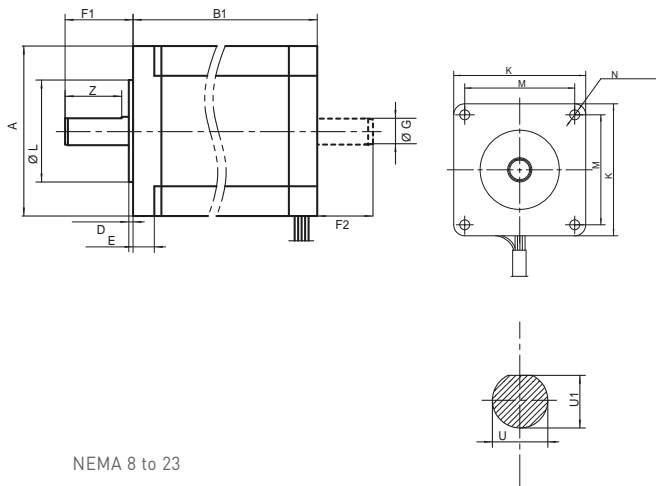

NEMA 8 to 23

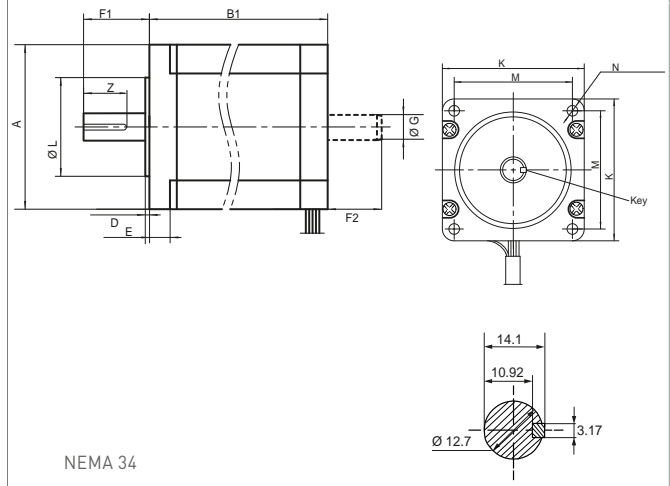

NEMA 34

Dimensions / Electrical and mechanical characteristics

NEMA	Size		Current/Phase	Resistance/Phase	Inductivity/Phase	AWG	max. voltage	Mechanical characteristics					Dimensions in mm														
	Edge dim.	Length						Holding torque	Detent torque	Rotor mass inertia	Bearing load		Mass	A ⁷⁾	B1 ⁸⁾	D	E	F1 ⁵⁾	F2 ⁴⁾	G ³⁾	K ⁷⁾	L ⁶⁾	M	N	U ²⁾	U1 ³⁾	Z
											axial ¹⁾	radial															
8	20-1	0.6	6.7	1.25	26	48	16	1	0.002	4	20	0.05	20.1	31.5	1.5	-	20	-	-	20.1	15	16	M2	4	-	-	
11	28-1	1.0	2.5	2.2	26	48	65	5	0.009	7	52	0.1	28.3	31	2	-	24	-	-	28.3	22	23	M2.5	5	4.5	15	
17	42-1	1.5	1.7	2.9	26	48	320	12	0.038	25/65	29	0.21	42.3	34.3	2	-	24	13	5	42.3	22	31	M3	5	4.5	15	
17	42-3	1.5	2.2	4.9	26	48	620	25	0.082	25/65	29	0.36	42.3	48.3	2	-	24	13	5	42.3	22	31	M3	5	4.5	15	
23	56-2	2.2	1.6	6.9	26	72	1500	45	0.22	40/130	70	0.69	56.4	55	1.6	4.8	20.6	13	6.35	56.4	38.1	47.1	5.1	6.35	5.8	15	
23	56-3	2.0	2.3	9.8	26	72	2300	75	0.39	40/130	70	1.0	56.4	77	1.6	4.8	20.6	13	6.35	56.4	38.1	47.1	5.1	6.35	5.8	15	
34	86-1	5.0	0.48	4.5	18	72	3800	90	0.95	65/155	220	1.6	86	67.5	1.25	10	31.7	19.05	9.52	86	73	69.6	6.5	12.7	-	22	
34	86-2	5.0	0.61	8	18	72	7200	150	1.6	65/155	220	2.7	86	97	1.25	10	31.7	19.05	9.52	86	73	69.6	6.5	12.7	-	22	

Valid for 20°C ambient temperature and atmospheric pressure.

¹⁾axial bearing load push / pull ²⁾tolerance: 0/-0.012 ³⁾tolerance: ±0.1 ⁵⁾tolerance: ±1 ⁶⁾tolerance: ±0.5 ⁷⁾tolerance: Nema 8 to 17: 0/-0.052; NEMA 23: ±0.05; NEMA 34: ±0.025

⁸⁾Nema 8 to 23: maximum; Nema 34: tolerance: ±0.5 ⁹⁾maximum

Frequency characteristics

phyBASIC 20-1 / NEMA 8
Half step mode

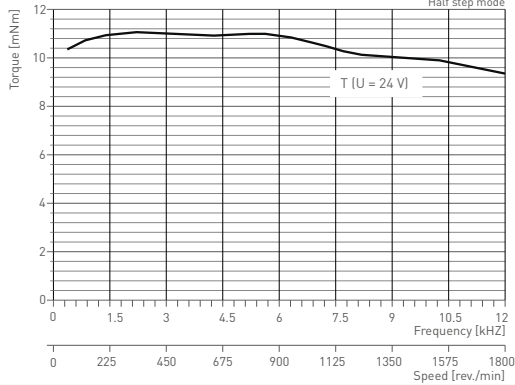

phyBASIC 28-1 / NEMA 11
Half step mode

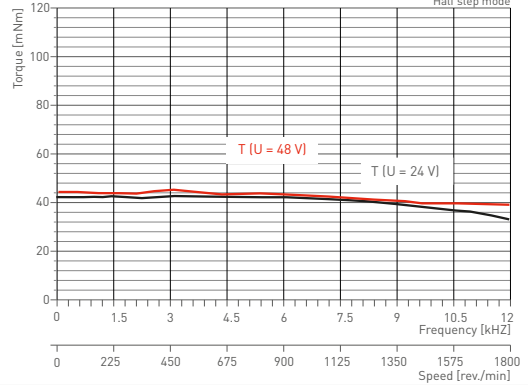

phyBASIC 42-1 / NEMA 17
Half step mode

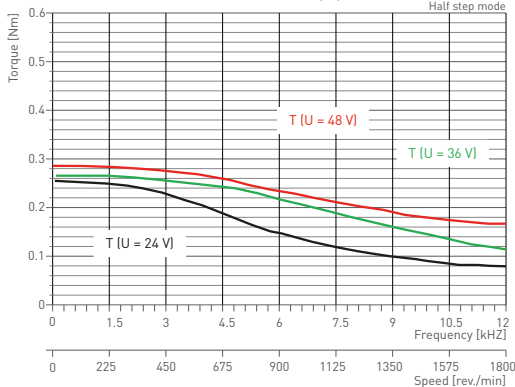

phyBASIC 42-3 / NEMA 17
Half step mode

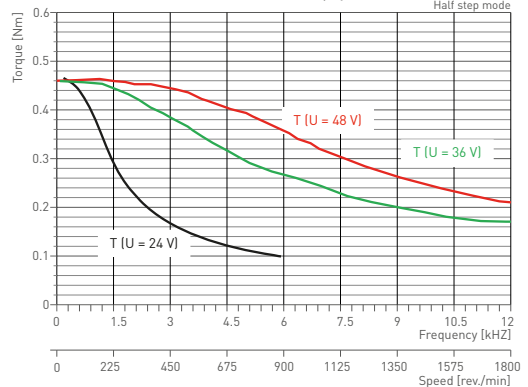

phyBASIC 56-2 / NEMA 23
Half step mode

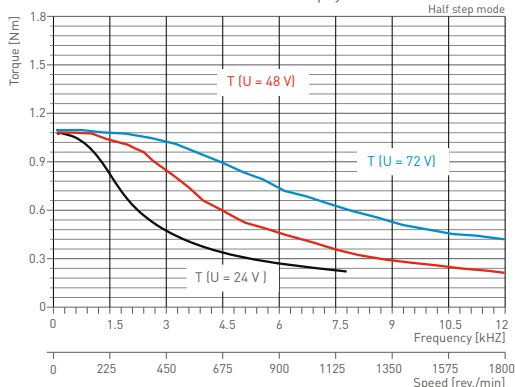

phyBASIC 56-3 / NEMA 23
Half step mode

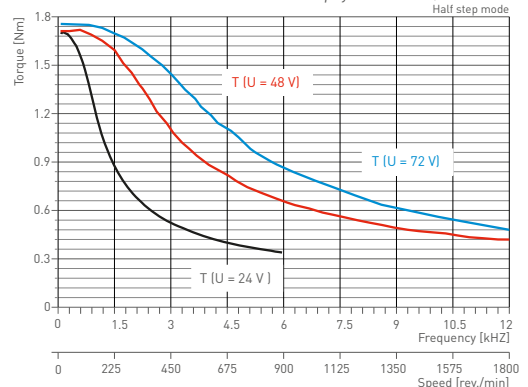

phyBASIC 86-1 / NEMA 34
Half step mode

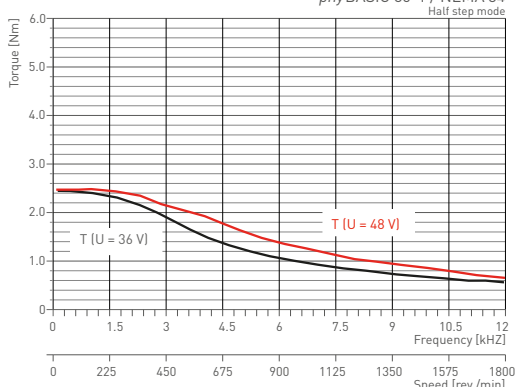

phyBASIC 86-2 / NEMA 34
Half step mode

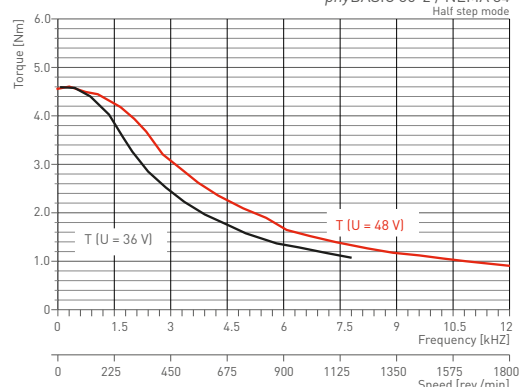

Industrial

Connectors and Mating connectors

Motor	Connector on the motor (pin)	Mating connector	
		Housing	Crimp contact
phyBASIC 20	JST B6B-ZR(LF)(SN)	JST ZHR-6	JST SZH-002T-P0,5
phyBASIC 28	MOLEX 53253-0670	P/N MOLEX 51065-0600	P/N MOLEX 50212-8000
phyBASIC 42	JST S6B-PH-K (LF)(SN)	JST PHR-6	JST SPH-002T-P0,5
phyBASIC 56	JST S6B-XH-A-1 (LF)(SN)	JST XHP-6	JST SXH-001T-P0,6
phyBASIC 86	Wire leads	-	-

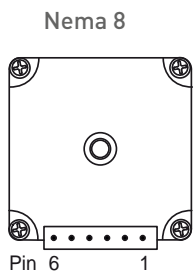

rear view

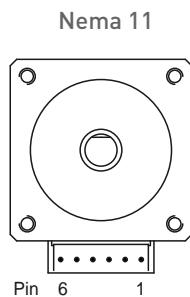

front view

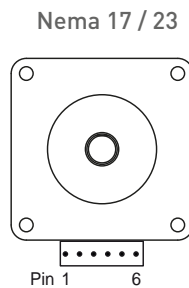

front view

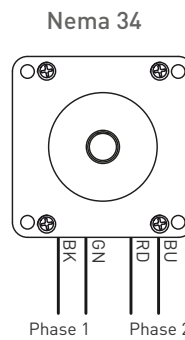

front view

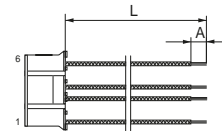

Mating connector JST-300/200

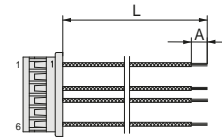

Mating connector MOLEX-300

All illustrations, descriptions and technical specifications are subject to modifications; no responsibility is accepted for the accuracy of this information.

Ordering Code

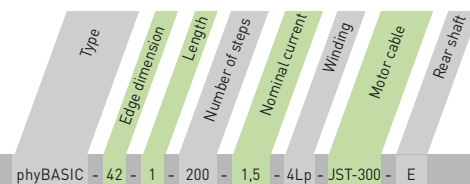

Ordering code example: phyBASIC - 42 - 1 - 200 - 1,5 - 4Lp - JST-300 - E

Options

Edge dimension [mm](NEMA)

- 20 (NEMA 8)
- 28 (NEMA 11)
- 42 (NEMA 17)

56 (NEMA 23)

86 (NEMA 34)

Ordering code

- phyBASIC-20-1-200-0,6-4Lp-JST-200
- phyBASIC-28-1-200-1,6-4Lp-MOLEX-300
- phyBASIC-42-1-200-1,5-4Lp-JST-300
- phyBASIC-42-3-200-1,5-4Lp-JST-300
- phyBASIC-56-2-200-2,2-4Lp-JST-300
- phyBASIC-56-3-200-2,0-4Lp-JST-300
- phyBASIC-86-1-200-5,0-4Lp-300
- phyBASIC-86-2-200-5,0-4Lp-300

Motor connection

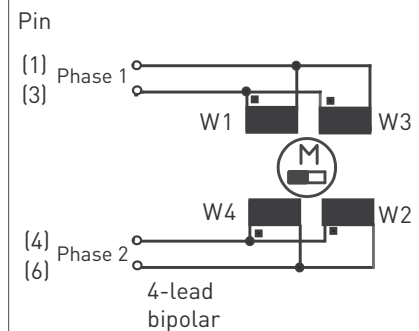

Equipment

- Cable with mating connector included

Phytron GmbH

Industriestraße 12 – 82194 Gröbenzell
 T +49-8142-503-0 F +49-8142-503-190