

## Programmable Stepper Motor Controller

### OMC/TMC Stepper Motor Controllers

The intelligent motion controllers OMC and TMC are small, simple and compact stepper motor control units for 2-phase stepper motors up to 9 A<sub>PEAK</sub> phase currents with 70 V motor voltage.

The connection of external power stages allows to connect larger stepper motors e. g. 17 A<sub>PEAK</sub> at 140 V motor voltage.

The controllers are applicable for more complex processes and motion sequences because of the circular interpolation and changes of frequency and target position during the run.

OMC offers 16 inputs, which are electrically isolated from the controller board, and 8 overload protected outputs.

TMC has 32 inputs and 16 outputs.

Two signal inputs are available for each axis to connect the limit switches.

The controllers can be supplied from 24 up to 70 V<sub>DC</sub> or 17 up to 50 V<sub>AC</sub>.

OMC and TMC are designed for DIN rail or

### Various Operation Modes

OMC/TMC are programmed in the well-tried MiniLog format.

The user-friendly MiniLog-Comm®, Windows® PC software for configuration and programming, is included in delivery.

A Remote/Local switch makes it possible to start and execute the saved program routines without connection to the superior control. Each OMC or TMC control unit can be used in single or multi-axis mode.

#### Stand-alone mode for single devices

The controller is able to execute program sequences without connection to PC.

#### Stand-alone multi-axis mode

Up to 30 axes can be simultaneously operated by PC: RS 422/RS 485-4-wire bus mode.

#### Master-slave mode

The connector with the address '0' is defined as master. The instructions are sent from the PC to the master and from the master to the slave controllers (up to 8 axes).

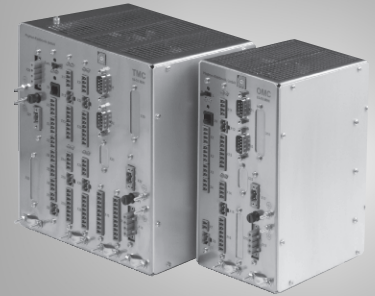

### Technical Information

- 1- or 2-axes stepper motor control unit for 2-phase stepper motors
- Linear and circular interpolation, Changes of the frequency and target position during the run
- Internal or external power stage
- Phase currents up to 9 A<sub>PEAK</sub>
- 4-quadrant precision current control
- Power supply  
50 V<sub>AC</sub> or 70 V<sub>DC</sub>
- Step resolution up to 1/20 step
- RS 232 interface (standard)  
RS 485/RS 422 interface (optional)
- Programming in well-tried MiniLog format and DIN 66025
- Remote or local mode
- Digital I/O  
OMC: 16 inputs / 8 outputs  
TMC: 32 inputs / 16 outputs
- Status LED
- Compact design
- Wall or DIN rail mounting
- Optional: SFI board  
AD converter  
Fan
- Accessories: PMC power supply  
External power stage  
Operator panel  
Ethernet adaptor  
USB-RS485 converter as stick

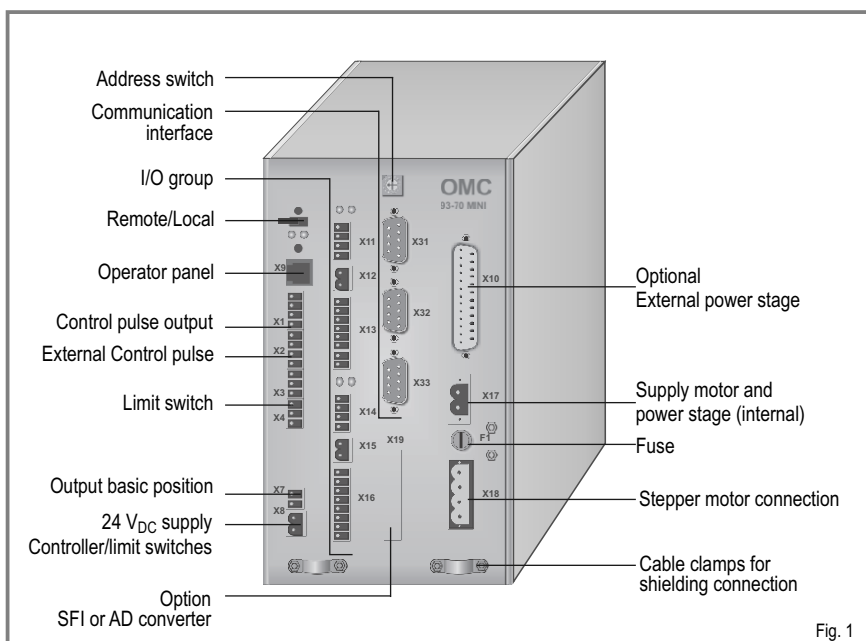
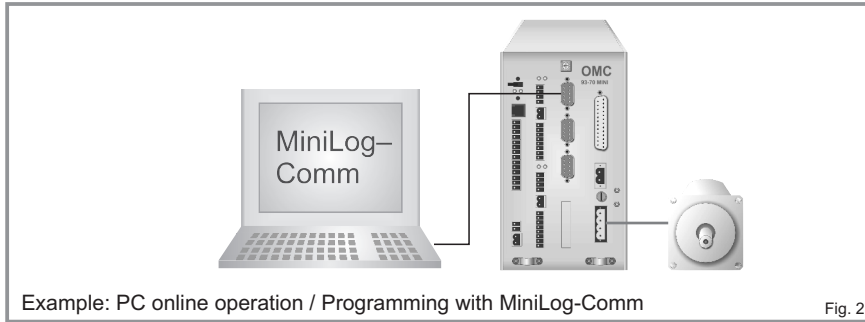

Fig. 1

## OMC Single Axis Controller / Stand-Alone Mode



## Controller Board

OMC/TMC are controlled by an 'intelligent' motion controller. This compact 'all-rounder' executes sequence programs, scans inputs, sets outputs and evaluates limit switch signals. Step resolution from 1/1 to 1/20 steps and linear or s-shaped positioning ramps are also set by the controller board.

The 24 V<sub>DC</sub> supply voltage for the controller board supplies simultaneously the limit switches.

## TMC Dual Axes Controller / internal / external Power Stage / Stand-Alone Mode

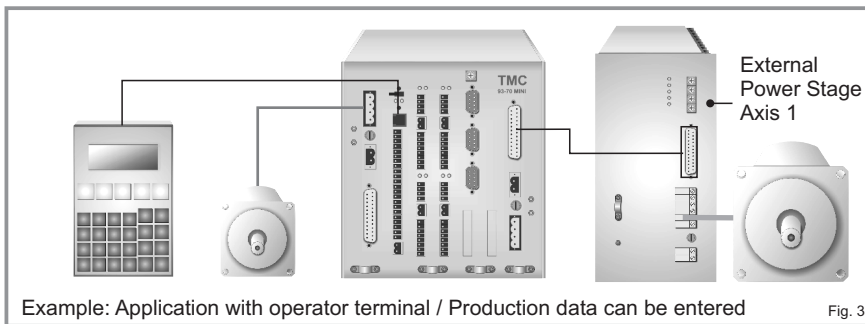

## Stepper Motor Power Stages

The controllers are equipped with internal or external power stages for bipolar operation according to the power requirements.

### Internal MOSFET Power Stages

4 quadrant chopper type precision current control

Step resolution from fullstep to 1/20 step

Phase currents from 0.14 to 9 A<sub>PEAK</sub>

Power supply of the power stages: AC or DC

### External Power Stages

For larger stepper motors it is possible to connect an external power stage: e. g. MSD MINI with 17 A/140 V.

The communication program MiniLog-Comm allows to scan the status of the power stage at any time.

## Multi-axes Controller / Bus Mode / Stand-Alone Mode

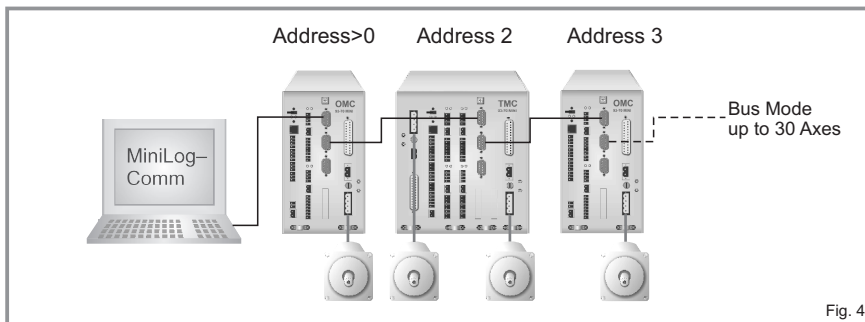

## Stepper Motor connected to internal Power Stage

Suitable stepper motors for operating with OMC/TMC:

- 2-phase stepper motors with 4-, 6- or 8-leads with 0.5 to 9 A<sub>PEAK</sub> phase current
- Resistance of a motor winding max. 10 Ω
- Inductivity of a motor phase 0.5 to 10 mH
- Motor currents, step resolution etc. are set by the MiniLog-Comm communication software.

## Master-Slave Combination 8 Axes

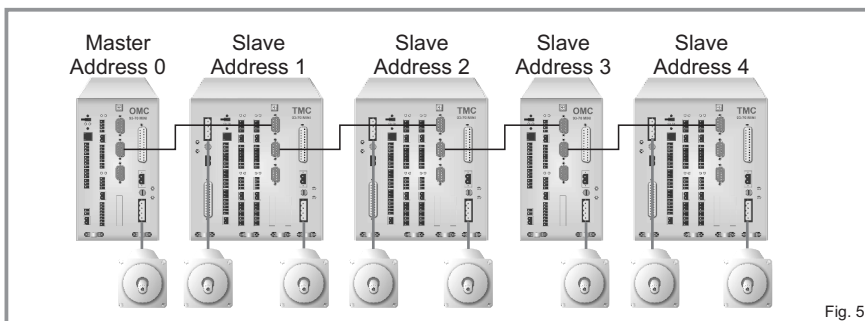

### Option SFI

- Step failure indication for stepper motors with encoder.
- Emergency stop in case of exceeding a given deviation between set and real position.
- For encoders with 2 or 3 cannels
- Power supply: +5 V<sub>DC</sub> / max. 150 mA per encoder is provided by the controller.

### Option AD Converter

- 14-bit-AD-converter board for connecting e. g. a joystick
- Input resistance: > 8 kOhm
- Max. current: 20 mA
- Resolution: 14 bit, digital value between 0 and 16384 incl. prefix
- Conversion time: 6 µsec
- OMC: 4 inputs  
TMC: 2x4 inputs
- Versions: Output voltage:  
0/+15 V (standard), +/- 15 V, 0/+5 V  
Input amplifier wiring: Measuring related to ground (standard) or differential
- Input wiring as 20 mA current interface

### Accessories: Ethernet Adaptor

OMC/TMC can be integrated by Ethernet Adaptor into the company's network. In order to watch or change the controller data via remote diagnostic.

### Accessories: Operator Panel BT



Fig. 9

### Dimensions OMC and TMC

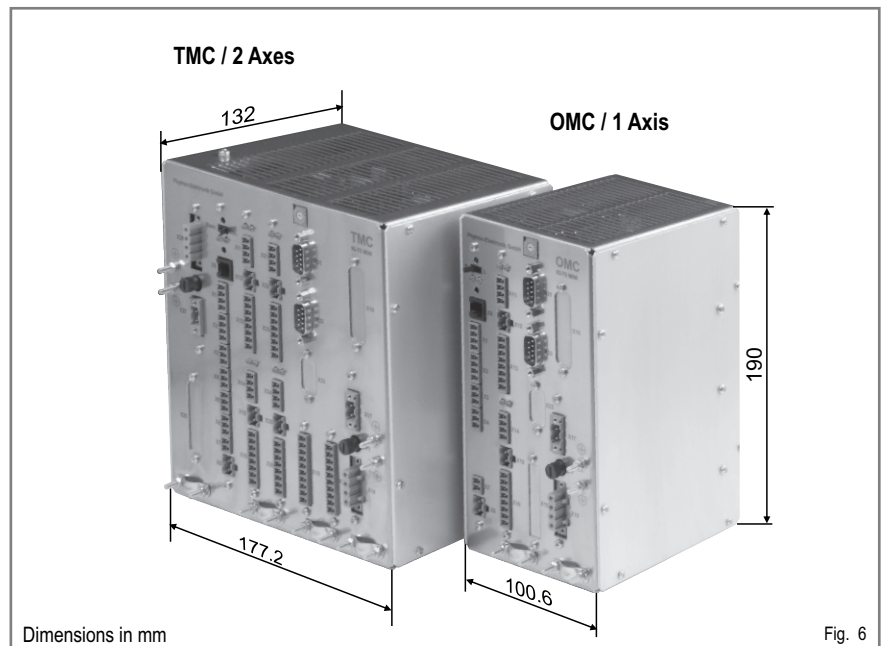

Fig. 6

### DIN Rail Mounting Clip

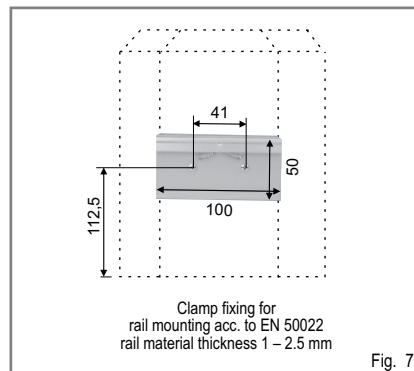

Fig. 7

### Wall Mounting Bracket

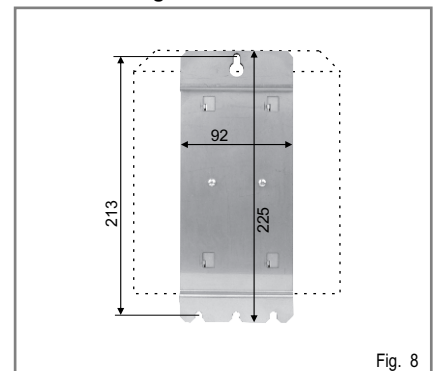

Fig. 8

### Operating Panel BT

The operator panel can be connected to the service interface port of OMC or TMC control units. During production, the operator can do some entries enabled for change: e. g. select other machine programs, adjust throughput, change quantities, etc.

If required, the operator panel displays text lines or error messages. Function keys can be individually labelled and are defined by the programmer.

In expert mode, additional functions are available, such as motion command inputs, output setting and status displays.

With only one operator panel at the master OMC or TMC, all connected control units in a master-slave system can be operated and monitored.

### MiniLog-Comm® Software

MiniLog-Comm, a Windows® PC software for configuring and programming, is included by delivery of the OMC/TMC controller.

MiniLog-Comm can set up parameters and execute program routines without PC connection.

Optionally, instructions can be handled by individual software. Readable ASCII string instructions and functions can be edited with LabView, Hyper Terminal or C language.

So it is possible to transmit parameters to each OMC/TMC during initialising or changing a module and evaluate the status signal.

### Performance Features of MiniLog-Comm:

- Editing sequential programming in MiniLog and DIN 66025 language (mixed as well)
- Customer programs can be transmitted to the controller and started without PC connection.
- Up to 2000 program lines
- Controller-specific parameters: e. g. motor currents, step resolution, run frequencies, acceleration ramps, counter, encoder settings
- Run instructions
- Axes initialising
- Sub-programs, jump instructions
- Reading and setting registers, logic operations
- Special instructions
- Dialog language selectable: English or German
- Test mode and status information
- Motion Creator converts the graphic of operational profiles in MiniLog programs
- CD and user manual included in delivery

### Accessories

- Assembly kit
- Connector set
- Cable assembly
- Power supply PMC
- Operator panel
- Ethernet Adaptor
- External power stages MSD MINI, SP MINI
- USB-RS485 converter as stick

### Example: MiniLog-Comm® Desktop

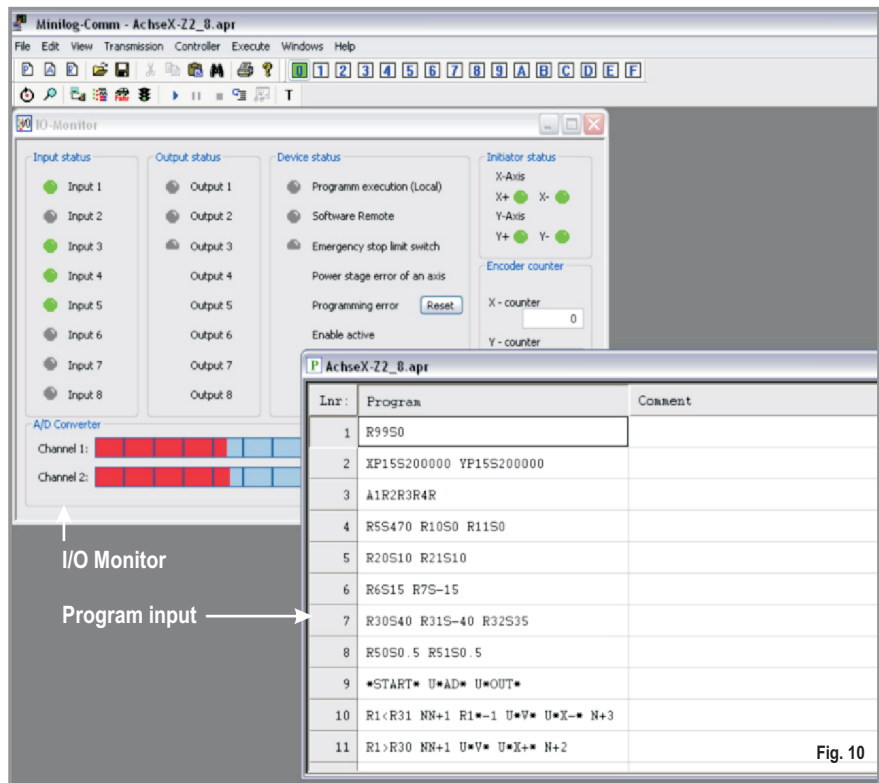

Fig. 10

### Ordering Code

**TMC - I / I - W - 232 - SF1 1 - F**

Type	O = One axis T = Two axes
	MC = Motion Controller
Power stage(s)	I/E = Internal/External
Mounting kit	H/W = Din rail (H) or wall mounting (W)
Interface	232 = RS 232, 485 = RS 485
Optional:	SF1/SF2 = Step failure indication for axis 1 and/or axis 2
Additional boards <sup>1</sup>	AD1x/AD2x = AD converter (7 types) for axis 1 and/or axis 2
Optional	F = 1 fan per axis

<sup>1</sup>One slot per axis for additional boards.

Example: AD1B/SF12  
Axis 1: AD converter type B  
Axis 2: SFI step failure indication

Available AD Converter Types (**bold** = Standard)

A	+15/-15 V	unipolar input
<b>B</b>	<b>+15/0 V</b>	
C	+5/0 V	
D	+15/-15 V	differential input
E	+15/0 V	
F	+5/0 V	20mA current loop
G	+15/0 V	