

LCM Specification

Preliminary specification

Final Specification

Project No. 项目编号	TFT-H040A6WVIST4N20		
Customer 客户名称			
Module No. 客户型号			
Product type 产品内容	TFT LCD Module 480 x 3RGB x 800 Dots 4.0" TFT LCD		
Signature by customer: 客户确认签章:			
<input type="checkbox"/> Trial production		<input type="checkbox"/> Mass production	
编 制	电子审核	结构审核	批 准
Y. L			

深圳市鑫洪泰电子科技有限公司

Shenzhen Hot Display Technology Co., Ltd

1 Document revision history :

DOCUMENT REVISION	DATE	DESCRIPTION	PREPARED BY	APPROVED BY
0	2020-09-15	First Release.	Y.L	

1. General Feature:

Item	Standard Value	Unit
Display Size	4.0"	--
Number of Pixels	480(H)x3(RGB)*800(V)	--
Active Area	51.84(H) *86.40(V)	mm
Outline Dimension	57.14(H) ×96.85× 2.10(V)	mm
Viewing Direction	FULL O'clock	-
Interface	Video MIPI 2L	-
LCM Driver IC	ST7701S	-
LCM Driver Condition	VCI=3.3V	V
Backlight	White LED	-
Touch Panel	Without Touch Panel	-
CTP Driver IC	---	
CTP Driver Condition	---	
Operation Temperature	-20~70	°C
Storage Temperature	-30~80	°C

2.Outline Dimensions

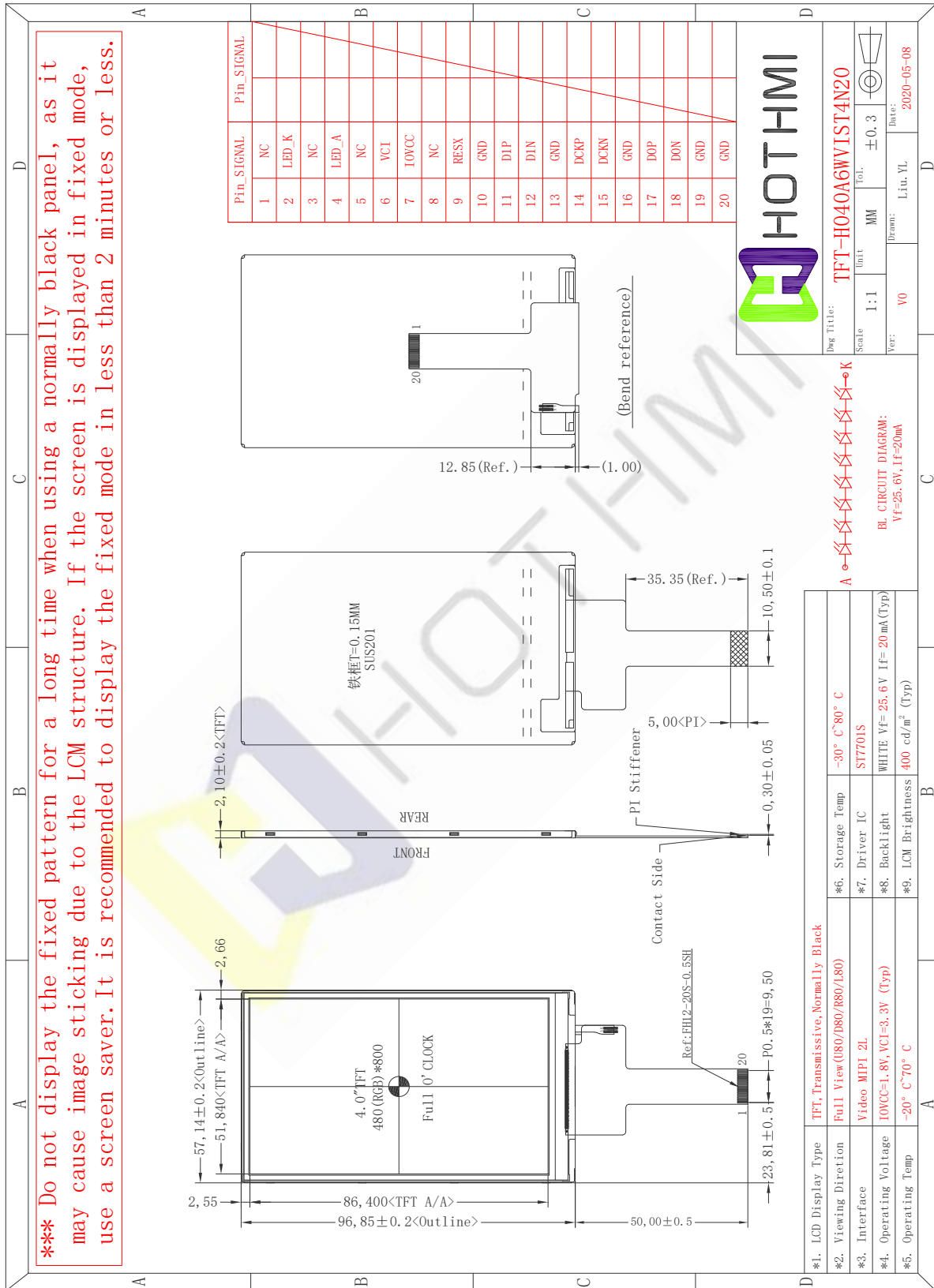

3. Pin Description

3.1 Pin Description

Pin NO.	Symbol	Description
1	NC	No Connector
2	LED_K	LED Cathode
3	NC	No Connector
4	LED_A	LED Anode
5	NC	No Connector
6	VCI	Analog Power(3.0 ~ 3.6 V)
7	IOVCC	Analog Power(1.65 ~ 3.6 V)
8	NC	No Connector
9	RESX	Reset input
10	GND	Ground
11	D1P	MIPI DSI differential data pair
12	D1N	MIPI DSI differential data pair
13	GND	Ground
14	DCKP	MIPI DSI differential clock pair
15	DCKN	MIPI DSI differential clock pair
16	GND	Ground
17	D0P	MIPI DSI differential data pair
18	D0N	MIPI DSI differential data pair
19	GND	Ground
20	GND	Ground

---END---

3.2 Wiring Diagram

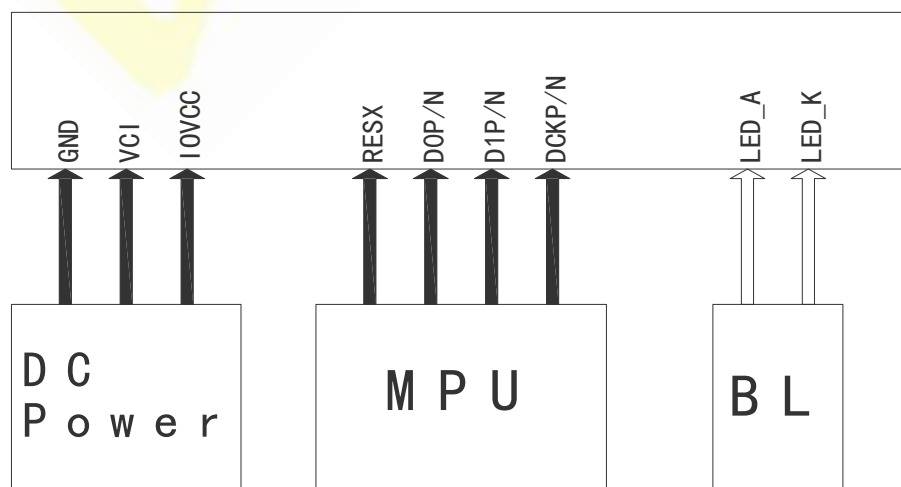

4. Electrical Characteristics

4-1 TFT LCD Module Operating Conditions

Item	Symbol	Condition	Min	Type	Max	Unit
Interface logic circuits	IOVCC	-	1.65	1.8	3.6	V
Analog Power supply	VCI	-	3.0	3.3	3.6	V
TFT Gate on voltage	VGH	-	10.0	-	16.0	V
TFT Gate off voltage	VGL	-	-16.0	-	-10.0	V

4-2 LED back light specification (pera chip)

Item	Symbol	Condition	Min	Type	Max	Unit
Forward voltage	Vt	If=20mA	22.4	25.6	28.8	V
Forward current	Ipn	/1-chip	-	20	-	mA
Luminance(With LCD)	Lv	If=20mA	300	400	-	cd/m ²
Luminous color	White					

4-3 CTP Operating Conditions

Item	Symbol	Condition	Min	Type	Max	Unit
Power Supply Voltages	VDD	-	2.8	3.30	3.60	V
I/O Digital Voltage	IOVDD	-	2.8	3.30	3.60	V

5. OPTICAL SPECIFICATION

5.1 Overview

The test of Optical specifications shall be measured in a dark room (ambient luminance 1lux and temperature = 25 ± 2°C) with the equipment of Luminance meter system (Goniometer system and TOPCON BM-5) and test unit shall be located at an approximate distance 50cm from the LCD surface at a viewing angle of θ and Φ equal to 0°. The center of the measuring spot on the Display surface shall stay fixed. The backlight should be operating for 30 minutes prior to measurement.

5.2 Optical Specifications

Parameter		Symbol	Condition	Min.	Typ.	Max.	Unit	Remark
Viewing Angle Range	Horizontal	Θ L	CR>10	-	80	-	Deg.	Note 1
		Θ R		-	80	-	Deg.	
	Vertical	Θ U		-	80	-	Deg.	
		Θ D		-	80	-	Deg.	
Contrast ratio		CR	$\Theta = 0^\circ$	720	900	-		Note2
Color Gamut		CG		65	70	-	%	
White Chromaticity		Wx			(0.310)			
		Wy			(0.336)			
Reproduction of color	Red	Rx	$\Theta = 0^\circ$	-0.02	(0.647)	+0.02		Note4 (Based on C Light)
		Ry			(0.317)			
	Green	Gx			(0.275)			
		Gy			(0.582)			
	Blue	Bx			(0.140)			
		By			(0.088)			
Response Time (Rising + Falling)		Tr+Tf	$\Theta = 0^\circ$ Ta= 25°C	-	35	45	ms	Note5
Transmittance(with Polarizer)		Tr		-	(4.14)	-	%	Note3

Note:

1.Viewing angle is the angle at which the contrast ratio is greater than 10. The viewing angles are determined for the horizontal or 3, 9 o' clock direction and the vertical or 6, 12 o' clock direction with respect to the optical axis which is normal to the LCD surface (see FIGURE 1).

2.Contrast measurements shall be made at viewing angle of $\Theta = 0$ and at the center of the LCD surface. Luminance shall be measured with all pixels in the view field set first to white, then to the dark (black)

state . (see FIGUR 1) Luminance Contrast Ratio (CR) is defined mathematically.

$$CR = \frac{\text{Luminance when displaying a white raster}}{\text{Luminance when displaying a black raster}}$$

3. Transmittance is the Value without APF and without CG.

4. The color chromaticity coordinates specified in the above table shall be calculated from the spectral data measured with all pixels first in red, green, blue and white. Measurements shall be made at the center of the panel.

5. The electro-optical response time measurements shall be made as FIGURE 2 by switching the “data” input signal ON and OFF. The times needed for the luminance to change from 10% to 90% is T_r , and 90% to 10% is T_f .

Figure1 Measurement Set Up

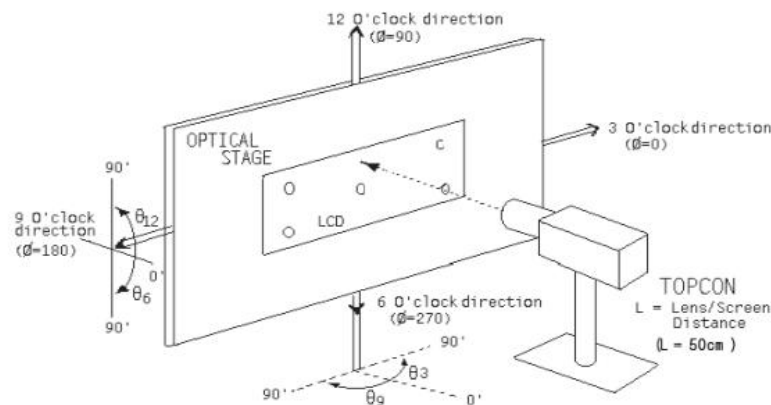
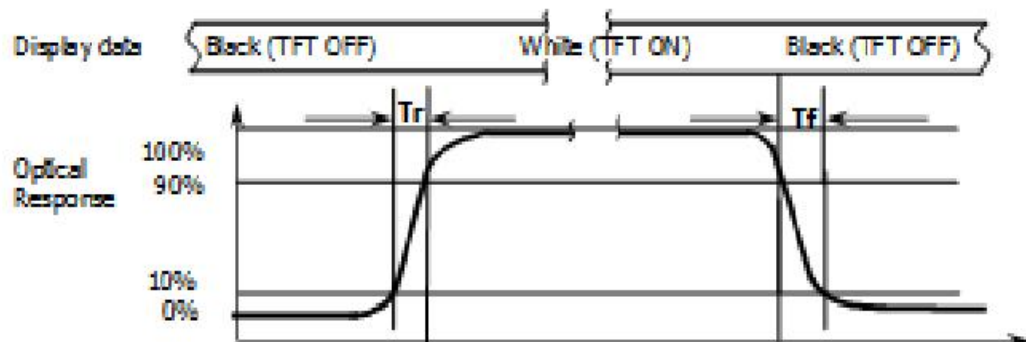
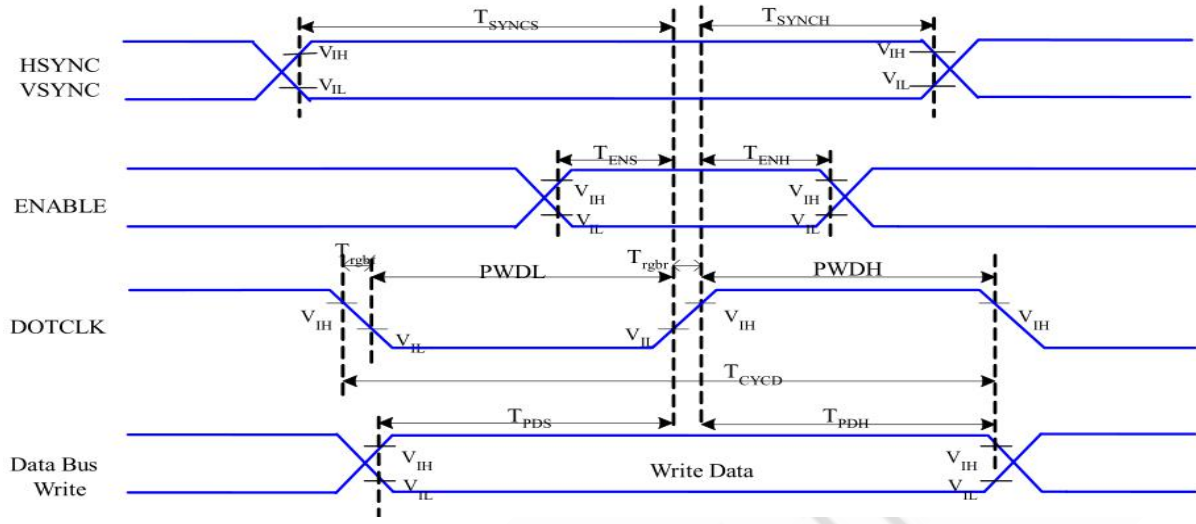

Figure2 Response Time Testing



6. Timing Characteristics of Input Signals

6-1 RGB Interface Characteristics



VDDI=1.8, VDD=2.8, AGND=DGND=0V, Ta=25 °C

Signal	Symbol	Parameter	MIN	MAX	Unit	Description
HSYNC, VSYNC	T _{SYNCS}	VSYNC, HSYNC Setup Time	5	-	ns	
ENABLE	T _{ENS}	Enable Setup Time	5	-	ns	
	T _{ENH}	Enable Hold Time	5	-	ns	
DOTCLK	PWDH	DOTCLK High-level Pulse Width	15	-	ns	
	PWDL	DOTCLK Low-level Pulse Width	15	-	ns	
	T _{CYCD}	DOTCLK Cycle Time	33	-	ns	
	Trghr, Trghf	DOTCLK Rise/Fall time	-	15	ns	
DB	T _{PDS}	PD Data Setup Time	5	-	ns	
	T _{PDH}	PD Data Hold Time	5	-	ns	

Please refer to the following table for the setting limitation of RGB interface signals.

Parameter	Symbol	Min.	Typ.	Max.	Unit
Horizontal Sync. Width	hpw	1	-	255	Clock
Horizontal Sync. Back Porch	hbp	1	--	255	Clock
Horizontal Sync. Front Porch	hfp	1	--	-	Clock
Vertical Sync. Width	vs	1	--	254	Line
Vertical Sync. Back Porch	vbp	1	--	254	Line
Vertical Sync. Front Porch	vfp	2	--	--	Line

Note:

1. Typical value are related to the setting frame rate is 60Hz..

6-2 MIPI Interface Characteristics

6-2-1 High Speed Mode



DSI clock channel timing

VDDI=1.8, VDD=2.8, AGND=DGND=0V, Ta=25 °C

Signal	Symbol	Parameter	MIN	MAX	Unit	Description
DSI-CLK+/-	$2xUI_{INSTA}$	Double UI instantaneous	4	25	ns	
DSI-CLK+/-	UI_{INSTA} UI_{INSTB}	UI instantaneous halves	2	12.5	ns	$UI = UI_{INSTA} = UI_{INSTB}$
DSI-Dn+/-	t _{DS}	Data to clock setup time	0.15	-	UI	
DSI-Dn+/-	t _{DH}	Data to clock hold time	0.15	-	UI	

Mipi Interface- High Speed Mode Timing Characteristics

6-2-1 Low Power Mode

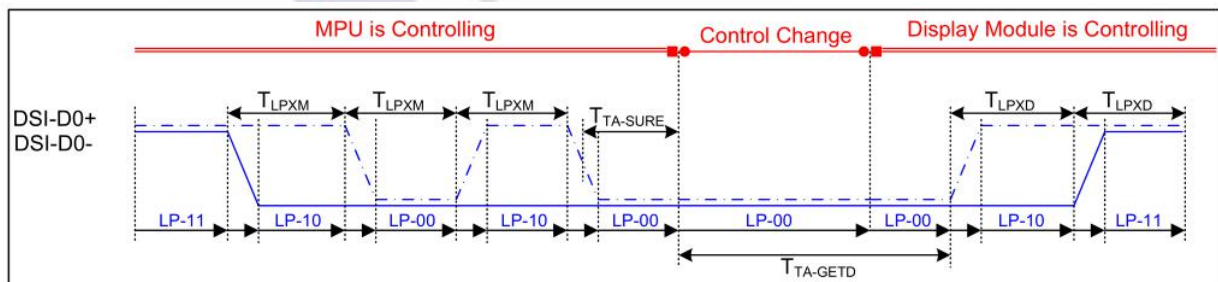

Bus Turnaround (BTA) from display module to MPU Timing

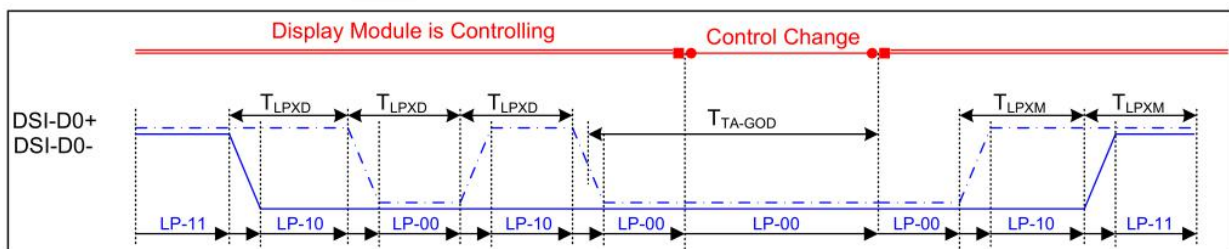

Bus Turnaround (BTA) from MPU to display module Timing

VDDI=1.8, VDD=2.8, AGND=DGND=0V, Ta=25 °C

Signal	Symbol	Parameter	MIN	MAX	Unit	Description
DSI-D0+/-	TLPXM	Length of LP-00,LP-01, LP-10 or LP-11 periods MPU→Display Module	50	75	ns	Input
DSI-D0+/-	TLPXD	Length of LP-00,LP-01, LP-10 or LP-11 periods MPU→Display Module	50	75	ns	Output
DSI-D0+/-	TTA-SURED	Time-out before the MPU start driving	T_{LPXD}	$2 \times T_{LPXD}$	ns	Output
DSI-D0+/-	TTA-GETD	Time to drive LP-00 by display module	$5 \times T_{LPXD}$		ns	Input
DSI-D0+/-	TTA-GOD	Time to drive LP-00 after turnaround request-MPU	$4 \times T_{LPXD}$		ns	Output

Mipi Interface Low Power Mode Timing Characteristics

6-2-1 DSI Bursts Mode

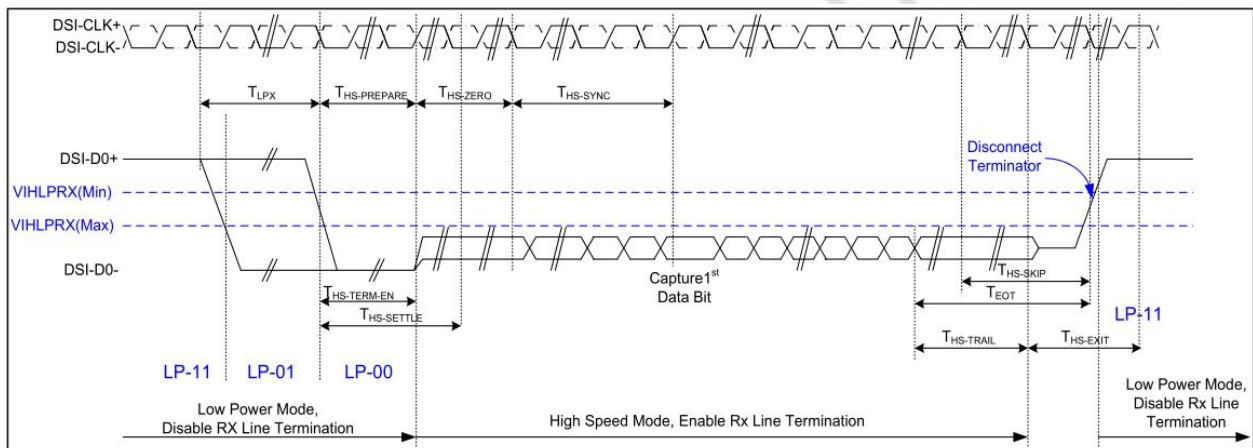

Data lanes-Low Power Mode to/from High Speed Mode Timing

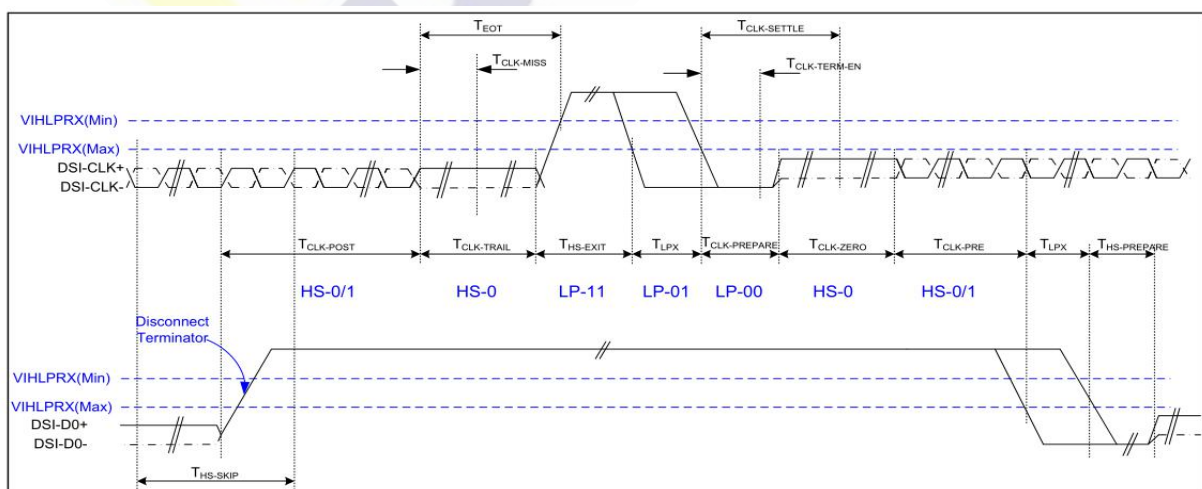

Clock lanes- High Speed Mode to/from Low Power Mode Timing

VDDI=1.8, VDD=2.8, AGND=DGND=0V, Ta=25 °C

Signal	Symbol	Parameter	MIN	MAX	Unit	Description
Low Power Mode to High Speed Mode Timing						
DSI-Dn+/-	TLPX	Length of any low power state period	50	-	ns	Input
DSI-Dn+/-	THS-PREPARE	Time to drive LP-00 to prepare for HS transmission	40+4 UI	85+6 UI	ns	Input
DSI-Dn+/-	THS-TERM-EN	Time to enable data receiver line termination measured from when Dn crosses VILMAX	-	35+4 UI	ns	Input
DSI-Dn+/-	THS-PREPARE + THS-ZERO	THS-PREPARE + time to drive HS-0 before the sync sequence	140+ 10UI	-	ns	Input
High Speed Mode to Low Power Mode Timing						
DSI-Dn+/-	THS-SKIP	Time-out at display module to ignore transition period of EoT	40	55+4 UI	ns	Input
DSI-Dn+/-	THS-EXIT	Time to drive LP-11 after HS burst	100	-	ns	Input
DSI-Dn+/-	THS-TRAIL	Time to drive flipped differential state after last payload data bit of a HS transmission burst	60+4 UI	-	ns	Input

High Speed Mode to/from Low Power Mode Timing						
DSI-CLK+/-	TCLK-POS	Time that the MPU shall continue sending HS clock after the last associated data lane has transition to LP mode	60+5 2UI	-	ns	Input
DSI-CLK+/-	TCLK-TRAIL	Time to drive HS differential state after last payload clock bit of a HS transmission burst	60	-	ns	Input
DSI-CLK+/-	THS-EXIT	Time to drive LP-11 after HS burst	100	-	ns	Input
DSI-CLK+/-	TCLK-PREPARE	Time to drive LP-00 to prepare for HS transmission	38	95	ns	Input
DSI-CLK+/-	TCLK-TERM-EN	Time-out at clock lan display module to enable HS transmission	--	38	ns	Input
DSI-CLK+/-	TCLK-PREPARE + TCLK-ZERO	Minimum lead HS-0 drive period before starting clock	300	-	ns	Input
DSI-CLK+/-	TCLK-PRE	Time that the HS clock shall be driven prior to any associated data lane beginning the transition from LP to HS mode	8UI	-	ns	Input
DSI-CLK+/-	TEOT	Time form start of TCLK-TRAIL period to start of LP-11 state	-	105n s+12 UI	ns	Input

7. RELIABILITY TEST

7-1 Temperature and Humidity

TEST ITEMS	CONDITIONS	NOTE
High Temperature Storage	Ta=+80 o C, 120hrs	
Low Temperature Storage	Ta=-30 o C, 120hrs	
High Temperature Operation	Ta=+70 o C, 120hrs	
Low Temperature Operation	Ta=-20 o C, 120hrs	
High Temperature and High Humidity (Operating)	Ta=+60 o C, 90%RH, 120hrs	

Note: (1) All tests above are practiced at module type.

(2) There is no display function NG issue occurred, all the cosmetic specification is judged before the reliability stress.

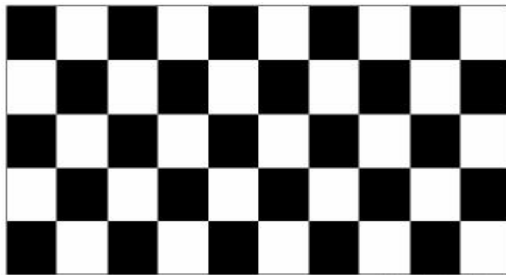

(a) Test Pattern (chess board Pattern)



(b) Gray Pattern

7-2 Shock and Vibration

ITEMS	CONDITIONS
Packing Shock (Non-Operation)	<ul style="list-style-type: none"> ● Shock level:980m/s² ● Waveform:1/2 Sine wave,6msec ● ±X, ±Y ±Z,each axis 1 times
Packing Vibration (Non-Operation)	<ul style="list-style-type: none"> ● Frequency range:8-33.3HZ ● Stoke:1.0mm ● Sweep: 10Hz-50Hz ● x,y,z 2 hours for each direction

7-3 Electrostatic Discharge

TEST ITEM	CONDITIONS
ESD (Non-operation)	150pF,330 Ω , Contact±4KV,Air :±8KV.Note 1
	200pF,0 Ω , ±200V Contact test.Note 2

Note:Measure Point:

- 1.LCD glass and metal bezel
- 2.IF connector pins

8. HANDLING & CAUTIONS

8-1 Caution For Operation

◆Since the LCM is made of glass, do not apply strong mechanical impact or static load onto it. Handling with care since shock, vibration, and careless handling may seriously affect the product. If it falls from a high place or receives a strong shock, the glass may be broken.

◆It is indispensable to drive the LCM within the specified voltage limit since the higher voltage than the limit causes LCM's life shorter. An electro-chemical reaction due to DC causes undesirable deterioration of the LCM so that the use of DC drive should be avoided.

◆Do not connect or disconnect the LCM to or from the system when power is on.

◆Never use the LCM under abnormal conditions of high temperature and high humidity.

◆When exposed to drastic fluctuation of temperature (hot to cold or cold to hot), the LCM may be affected; specifically, drastic temperature fluctuation from cold to hot, produces dew on the LCM's surface which may affect the operation of the polarizer on the LCM.

◆Response time will be extremely delayed at lower temperature than the operating temperature range and on the other hand LCM may turn black at temperature above its operational range. However those phenomena do not mean malfunction or out of order with the LCM. The LCM will revert to normal operation once the temperature returns to the recommended temperature range for normal operation.

◆Do not display the fixed pattern for a long time when using a normally black panel, as it may cause image sticking due to the LCM structure. If the screen is displayed in fixed mode, use a screen saver. It is recommended to display the fixed mode in less than 2 minutes or less.

◆Do not disassemble and/or re-assemble LCM module

7-2 Caution Against Static Charge

◆The LCM uses C-MOS LSI drivers, so customers are recommended that any unused input terminal would be connected to V_{DD} or V_{SS}, do not input any signals before power is turned on, and ground your body, work/assembly area, assembly equipments to protect against static electricity.

◆Remove the protective film slowly, keeping the removing direction approximate 30-degree not vertical from panel surface, if possible, under ESD control device like ion blower, and the humidity of working room should be kept over 50%RH to reduce the risk of static charge.

◆Avoid the use of work clothing made of synthetic fibers. We recommend cotton clothing or other conductivity-treated fibers.

◆In handling the LCM, wear non-charged material gloves. And the conducting wrist to the earth and the conducting shoes to the earth are necessary

9. LCD display initialization code

```
Void Panel_initial_code(void)
{
//Panel:4.0
//Resulation: 480*800
//External system porch setting: 125>VBP>=17,VFP>=6
//Line Time:20 us
//Frame Rate: 60 Hz
//-----Reset sequence-----//
LCD_RESET=1;
Delaysms Delay(1); //Delay 1ms
LCD_RESET=0;
Delaysms (10); //Delay 10ms
LCD_RESET=1;
Delaysms (120); //Delay 120ms
//-----//
WriteComm (0x11);
Delaysms (120);
WriteComm (0xFF);
WriteData (0x77);
WriteData (0x01);
WriteData (0x00);
WriteData (0x00);
WriteData (0x10);

WriteComm (0xC0);
WriteData (0x63);
WriteData (0x00);
WriteComm (0xC1);
WriteData (0x11);
WriteData (0x02);
WriteComm (0xC2);
WriteData (0x31);
WriteData (0x08);
WriteComm (0xCC);
WriteData (0x10);
WriteComm (0xB0);
WriteData (0x00);
WriteData (0x05);
```

WriteData (0x0F);
WriteData (0x0D);
WriteData (0x13);
WriteData (0x07);
WriteData (0x01);
WriteData (0x08);
WriteData (0x09);
WriteData (0x1E);
WriteData (0x05);
WriteData (0x12);
WriteData (0x10);
WriteData (0xB2);
WriteData (0x2F);
WriteData (0x18);
WriteComm (0xB1);
WriteData (0x00);
WriteData (0x0F);
WriteData (0x17);
WriteData (0x0C);
WriteData (0x0D);
WriteData (0x05);
WriteData (0x01);
WriteData (0x08);
WriteData (0x08);
WriteData (0x1E);
WriteData (0x05);
WriteData (0x13);
WriteData (0x11);
WriteData (0xB2);
WriteData (0x2F);
WriteData (0x18);
WriteComm (0xFF);
WriteData (0x77);
WriteData (0x01);
WriteData (0x00);
WriteData (0x00);
WriteData (0x11);
WriteComm (0xB0);
WriteData (0x6C);
WriteComm (0xB1);

WriteData (0x5D);
WriteComm (0xB2);
WriteData (0x07);
WriteComm (0xB3);
WriteData (0x80);
WriteComm (0xB5);
WriteData (0x47);
WriteComm (0xB7);
WriteData (0x85);
WriteComm (0xB8);
WriteData (0x20);
WriteComm (0xB9);
WriteData (0x10);
WriteComm (0xC1);
WriteData (0x78);
WriteComm (0xC2);
WriteData (0x78);
WriteComm (0xD0);
WriteData (0x88);
Delays (100);
WriteComm (0xE0);
WriteData (0x00);
WriteData (0x00);
WriteData (0x02);
WriteComm (0xE1);
WriteData (0x08);
WriteData (0x00);
WriteData (0x0A);
WriteData (0x00);
WriteData (0x07);
WriteData (0x00);
WriteData (0x09);
WriteData (0x00);
WriteData (0x00);
WriteData (0x33);
WriteData (0x33);
WriteComm (0xE2);
WriteData (0x00);
WriteData (0x00);
WriteData (0x00);

WriteData (0x00);
WriteData (0x00);
WriteData (0x00);
WriteData (0x00);
WriteData (0x00);
WriteData (0x00);
WriteData (0x00);
WriteData (0x00);
WriteData (0x00);
WriteComm (0xE3);
WriteData (0x00);
WriteData (0x00);
WriteData (0x33);
WriteData (0x33);
WriteComm (0xE4);
WriteData (0x44);
WriteData (0x44);
WriteComm (0xE5);
WriteData (0x0E);
WriteData (0x60);
WriteData (0xA0);
WriteData (0xA0);
WriteData (0x10);
WriteData (0x60);
WriteData (0xA0);
WriteData (0xA0);
WriteData (0x0A);
WriteData (0x60);
WriteData (0xA0);
WriteData (0xA0);
WriteData (0x0C);
WriteData (0x60);
WriteData (0xA0);
WriteData (0xA0);
WriteComm (0xE6);
WriteData (0x00);
WriteData (0x00);
WriteData (0x33);
WriteData (0x33);

WriteComm (0xE7);
WriteData (0x44);
WriteData (0x44);
WriteComm (0xE8);
WriteData (0x0D);
WriteData (0x60);
WriteData (0xA0);
WriteData (0xA0);
WriteData (0x0F);
WriteData (0x60);
WriteData (0xA0);
WriteData (0xA0);
WriteData (0x09);
WriteData (0x60);
WriteData (0xA0);
WriteData (0xA0);
WriteData (0x0B);
WriteData (0x60);
WriteData (0xA0);
WriteData (0xA0);
WriteComm (0xEB);
WriteData (0x02);
WriteData (0x01);
WriteData (0xE4);
WriteData (0xE4);
WriteData (0x44);
WriteData (0x00);
WriteData (0x40);
WriteComm (0xEC);
WriteData (0x02);
WriteData (0x01);
WriteComm (0xED);
WriteData (0xAB);
WriteData (0x89);
WriteData (0x76);
WriteData (0x54);
WriteData (0x01);
WriteData (0xFF);
WriteData (0xFF);
WriteData (0xFF);

```
WriteData (0xFF);  
WriteData (0xFF);  
WriteData (0xFF);  
WriteData (0x10);  
WriteData (0x45);  
WriteData (0x67);  
WriteData (0x98);  
WriteData (0xBA);  
WriteComm (0xFF);  
WriteData (0x77);  
WriteData (0x01);  
WriteData (0x00);  
WriteData (0x00);  
WriteData (0x00);
```

```
WriteComm (0x29);  
Delaysms(150);  
}
```

Void Sleep in (void)

```
{  
WriteComm (0x28); //Enter display off  
Delaysms (120); //Delay 120ms  
WriteComm (0x10); //Enter sleep in  
Delaysms (120); //Delay 120ms  
}
```

Void Sleep out (void)

```
{  
WriteComm (0x11); //Enter sleep out  
Delaysms (120); //Delay 120ms  
WriteComm (0x29); //Enter display on  
Delaysms (120); //Delay 120ms  
}
```

--END--